

---

**MODEL 1200R PLOTTER  
USER'S MANUAL**

---

***ATLANTEK***®

**Manual No. 753013 Rev 3**

**COPYRIGHT © 1998 by ATLANTEK INC.**

---

## Notice

The information contained in this document is subject to change without notice. Atlantek makes no warranty of any kind with regard to this material, including, but not limited to, the implied warranties of merchantability and fitness for a particular purpose. No patent liability is assumed with respect to the use of the information contained herein.

Atlantek shall not be liable for errors contained herein or for incidental or consequential damages in connection with the furnishing, performance or use of this material.

All rights reserved. No part of this document may be photocopied, reproduced or translated to another language without the prior written consent of Atlantek Inc.

---

## **Model 1200R-A User's Manual** **Atlantek Publication No: 753013 Rev 3**

---

### Printing History:

Original Release (Rev 1)	7 February 1996
Rev 2	13 March 1996
Rev 3	27 April 1998

---

**COPYRIGHT © 1998 by ATLANTEK INC.**  
**10 High Street, Wakefield, RI, 02879 USA**

Doc't No.: MAN12L\_3.DOC

---

## Regulatory Notices

This device complies with Part 15 of the FCC Rules. Operation is subject to the following two conditions: (1) this device may not cause harmful interference, and (2) this device must accept any interference received, including interference that may cause undesired operation.

**Warning:** Changes or modification to this unit not expressly approved by the party responsible for compliance could void the user's authority to operate the equipment.

**Note:** This equipment has been tested and found to comply with the limits for a Class A digital device, pursuant to Part 15 of the FCC Rules. These limits are designed to provide reasonable protection against harmful interference when the equipment is operated in a commercial environment. This equipment generates, uses, and can radiate radio frequency energy and, if not installed and used in accordance with the instruction manual, may cause harmful interference to radio communications. Operation of this equipment in a residential area is likely to cause harmful interference in which case the user will be required to correct the interference at his own expense.

Shielded cables must be used with this unit to ensure compliance with the Class A FCC limits.

---

This equipment has been designed to meet or exceed the requirements of the UL 1950 safety specification.

---

## Acknowledgments

"Versatec" is a trademark of Xerox Inc.

"Wetordry" is a trademark of 3M Inc.

---

## References

Versatec™, *Electrostatic Printer/Plotter Interface Specifications, Bulletin No. 312*, September 1977

Versatec™, *V-80 Series Electrostatic Printer/Plotter Specifications, Bulletin No. 470*, December 1979

---

## Warranty

**Atlantek, Inc.** warrants its products to be free of defects in material and workmanship under normal use conditions for a period of one (1) year commencing the date of shipment from its factory. Given notice and upon confirmation of such defects, Atlantek will, at its option, either repair or replace the defective product.

---

## Exclusions

This warranty does not apply to defects resulting from: improper or inadequate maintenance by customer; misuse, abuse, alteration; unauthorized or improper service; operation outside the specified environmental range; improper shipping or installation; and use of unqualified media. This warranty does not apply to normal wear items such as friction pads, belts, and platen.

The thermal printhead is warranted for a period of one (1) year with prorated replacement based upon the actual percentage of normalized printhead life utilized. The printhead carries a normalized life of 50 kilometers (31 miles, approx.) of media passed under the printhead. When reporting a printhead failure, the customer must provide the "Line Count" and "Dot Count" readings from the plotter display. Procedure for reading these counts is described in this manual (see Section 8.7). Prorated printhead replacement during the original warranty is based upon the following schedule:

Distance run -- based upon displayed Line Count:	Allowance for defective printhead:
0 to 24.9 km	100%
25.0 to 49.9 km	75%
50.0 to 74.9 km	30%
75.0 km or more	no allowance

The above warranty shall not apply to the thermal printhead used in the plotter when the thermal printhead has been judged to have been damaged by improper cleaning, or operated with improperly dried media.

---

## Warranty Limitations

Atlantek makes no other warranty, either expressed or implied, with respect to this product. Atlantek specifically disclaims the implied warranties of merchantability and fitness for a particular purpose. Atlantek will not be liable for any special, indirect, incidental or consequential damages or loss, including loss of data from failure of the product. Some states or provinces do not allow limitations on the duration of an implied warranty, so the above limitations may not apply to you. However, any implied warranty of merchantability or fitness is limited to the one year duration of this written warranty.

---

## Claims procedure

If an Atlantek plotter should fail, follow the instructions in the Troubleshooting section within this manual. If you are unable to solve or determine the cause of the problem contact the Atlantek service department at (401) 783-5700. You should have the plotters model and serial numbers available when you call, also the processor and controller PCB's revision level maybe needed. The revision levels are listed on the inspection form sent with the unit or can be determined via the front panel by referring to Section 8 and 8.2 of this manual. If we cannot solve the problem we will provide a return authorization (RA) number. Under this RA# the

nature of the reported problem is documented, and Atlantek authorizes receipt of the incoming defective plotter. This RA# must be prominently noted with the product returned for service. The defective product is to be shipped freight-prepaid to Atlantek's address (given below). Atlantek will repair or replace the defect within 30 days and return it freight-prepaid to the customer for in warranty repairs only. The customer shall pay all shipping charges, duties and taxes for a plotter returned from another country. Warranty repair service is provided only to the original purchaser. If the plotter has been leased or purchased through a third party, contact the lessor or third party for servicing.

If a defective part or subassembly is returned for repair or replacement, the same RA# procedure is followed. The defective part or assembly is returned freight-prepaid to Atlantek. Atlantek will repair or replace the item within 2 days and return it freight-prepaid to the customer. To minimize time out of service, the customer may elect to order the part or assembly with a purchase order. Atlantek will ship and invoice for the part or assembly, and will issue credit to the customer upon receipt and confirmation of the defective part fault at its factory.

Telephone and freight address information for Atlantek, Inc. is as follows:

**Atlantek, Inc.**  
**10 High Street, Wakefield, RI 02879 USA**  
**Tel: (401) 783-5700, Fax: (401) 783-9881**

Claims for shipping damage must be made by the customer to the carrier. The customer should thoroughly inspect the product immediately upon original delivery and, if damaged in any way, should file a claim with the carrier. Atlantek will upon request provide a quote to repair shipping damage.

---

**Table of Contents**

<b>Regulatory Notices</b> . . . . .	Page iii
<b>Acknowledgments</b> . . . . .	Page iii
<b>References</b> . . . . .	Page iii
<b>Warranty</b> . . . . .	Page iv
<b>1. Introduction</b> . . . . .	Page 1
<b>2. Specifications</b> . . . . .	Page 4
<b>3. Installation</b> . . . . .	Page 5
3.1 Receiving Inspection . . . . .	Page 5
3.2 Line Power Input Requirements . . . . .	Page 6
3.3 Line Voltage Selection . . . . .	Page 6
3.4 Data Interface Configuration . . . . .	Page 7
<b>4. Basic Operation and Controls</b> . . . . .	Page 8
4.1 Printhead Lift Mechanism . . . . .	Page 8
4.2 Loading Media . . . . .	Page 8
4.3 Printhead Cleaning . . . . .	Page 10
4.4 Front Panel Indicators and Controls . . . . .	Page 11
4.4.1 Pushbutton Keys . . . . .	Page 11
4.4.2 Alphanumeric Display . . . . .	Page 12
4.4.3 Indicator Lamps . . . . .	Page 12
4.5 Side Panel Functions . . . . .	Page 13
4.6 Protective Sensors and Operator Interaction . . . . .	Page 14
4.7 Initial Power-Up . . . . .	Page 16
<b>5. Data Interface</b> . . . . .	Page 17
5.1 Parallel Interface Signals . . . . .	Page 17
5.2 Handshake Protocol . . . . .	Page 22
5.2.1 Plot Mode . . . . .	Page 23
5.2.2 Print Mode . . . . .	Page 24
5.2.3 Plot/Print Mode Changes . . . . .	Page 25
5.3 Internal Character Set . . . . .	Page 25
<b>6. Operational States</b> . . . . .	Page 28
6.1 Initialization (Power-Up) State . . . . .	Page 29
6.2 Online State . . . . .	Page 32
6.2.1 Online State Keypad/Display Functions . . . . .	Page 32
6.2.2 Sensor faults . . . . .	Page 33
6.2.3 Online State Output Speed . . . . .	Page 33
6.3 Offline State . . . . .	Page 34
6.3.1 Offline State Keypad/Display Functions . . . . .	Page 34
6.3.2 Sensor faults . . . . .	Page 36
6.3.3 Offline State Output Speed . . . . .	Page 36
6.4 Alarm State . . . . .	Page 37
6.4.1 Responses to common Sensor Faults . . . . .	Page 37
6.4.2 Alarm State Media Feed . . . . .	Page 39
6.5 Trap Report State . . . . .	Page 40
6.6 Configuration State . . . . .	Page 41

- 7. Configuration -- User Menu** . . . . . Page 43
  - 7.1 Energy Level Selection . . . . . Page 43
  - 7.2 Test Pattern Selection . . . . . Page 44
  - 7.3 Chart Speed Limiting . . . . . Page 46
  - 7.4 Media Sensor Enable/Disable . . . . . Page 47
  - 7.5 Plot Width . . . . . Page 48
  - 7.6 Plot Location . . . . . Page 48
  - 7.7 Print Width . . . . . Page 49
  - 7.8 Print Location . . . . . Page 49
  - 7.9 Dither Control . . . . . Page 50
  - 7.10 Media Counter Mode . . . . . Page 50
  - 7.11 Display Units Mode . . . . . Page 51
  - 7.12 Media Reset Length . . . . . Page 51
  - 7.13 Form Feed Length . . . . . Page 52
  - 7.14 End-of-Transmission Feed Length . . . . . Page 52
  - 7.15 Default Power-Up State Control . . . . . Page 53
  - 7.16 Self-Test Output Speed Control . . . . . Page 53
  
- 8. Configuration -- Service Menu** . . . . . Page 54
  - 8.1 Printhead Temperature Report . . . . . Page 54
  - 8.2 Software Status Report . . . . . Page 55
  - 8.3 Rotation Sense Mask Report . . . . . Page 56
  - 8.4 Printhead Serial Number . . . . . Page 56
  - 8.5 Printhead Segment Resistance Entry . . . . . Page 56
  - 8.6 Print Voltage Setpoint Reference . . . . . Page 57
  - 8.7 Odometer Count Reports . . . . . Page 57
  - 8.8 Internal Diagnostics . . . . . Page 58
  - 8.9 Power-Up Self-Test Error Code . . . . . Page 58
  
- 9. Media** . . . . . Page 59
  
- 10. Service** . . . . . Page 61
  - 10.1 Major Functional Components . . . . . Page 61
  - 10.2 Removal / Replacement Instructions . . . . . Page 63
  - 10.3 Service Mode Self-Test Patterns . . . . . Page 66
  - 10.4 Power Supply Adjustment / Configuration . . . . . Page 66
  - 10.5 Printhead Replacement and Alignment . . . . . Page 69
  - 10.6 Controller Board Sensor Adjustment . . . . . Page 72
  - 10.7 Troubleshooting . . . . . Page 75
    - 10.7.1 Controller Board Indicators . . . . . Page 78
    - 10.7.2 Controller Board Isolated Test . . . . . Page 79
    - 10.7.3 Processor Board Power-Up Test Error Codes . . . . . Page 80

---

**Figures**

Figure 1 -- Atlantek Model 1200R Plotter . . . . .	Page 1
Figure 2 -- Media Threading Path . . . . .	Page 8
Figure 3 -- Front Control Panel . . . . .	Page 11
Figure 4 -- Right-Hand Side Panel . . . . .	Page 13
Figure 5 -- Data Interface Configurations . . . . .	Page 18
Figure 6 -- Interface Handshake Timing . . . . .	Page 23
Figure 7 -- Model 1200R Plotter Wiring Diagram . . . . .	Page 82

---

**Tables**

Table 1 -- Interface Connector Pin Assignment . . . . .	Page 19
Table 2 -- Interface Signals and Functions . . . . .	Page 20
Table 3 -- Internal Character Set and Code Assignment . . . . .	Page 26
Table 4 -- Summary for Initialization State . . . . .	Page 29
Table 5 -- Summary for Online State . . . . .	Page 32
Table 6 -- Summary for Offline State . . . . .	Page 34
Table 7 -- Summary for Alarm State . . . . .	Page 37
Table 8 -- Summary for Configuration State . . . . .	Page 41
Table 9 -- Energy Level Characteristics . . . . .	Page 43
Table 10 - Thermal Media Reference . . . . .	Page 59
Table 11 - Print Voltage Lookup Reference . . . . .	Page 68
Table 12 - Troubleshooting Guide . . . . .	Page 75
Table 13 - Power-Up Error Codes . . . . .	Page 80

# 1. Introduction

## 1.1 Scope

This manual contains information necessary to install and operate the **Atlantek Model 1200R Thermal Plotter** (Firmware Series A), as shown in Figure 1. The functionality described in this manual is fully implemented with the following internal logic microprocessor software revision levels:

Manual Document Num./Rev.:	753013 Rev 3
Date Released:	27 April 1998
Processor Board Software Rev:	A2.6
Controller Board Software Rev:	A2.7

The manual is intended for use by operator and service personnel. However, only qualified service personnel should be allowed to install and service this equipment.

**Figure 1 -- Atlantek Model 1200R Plotter**

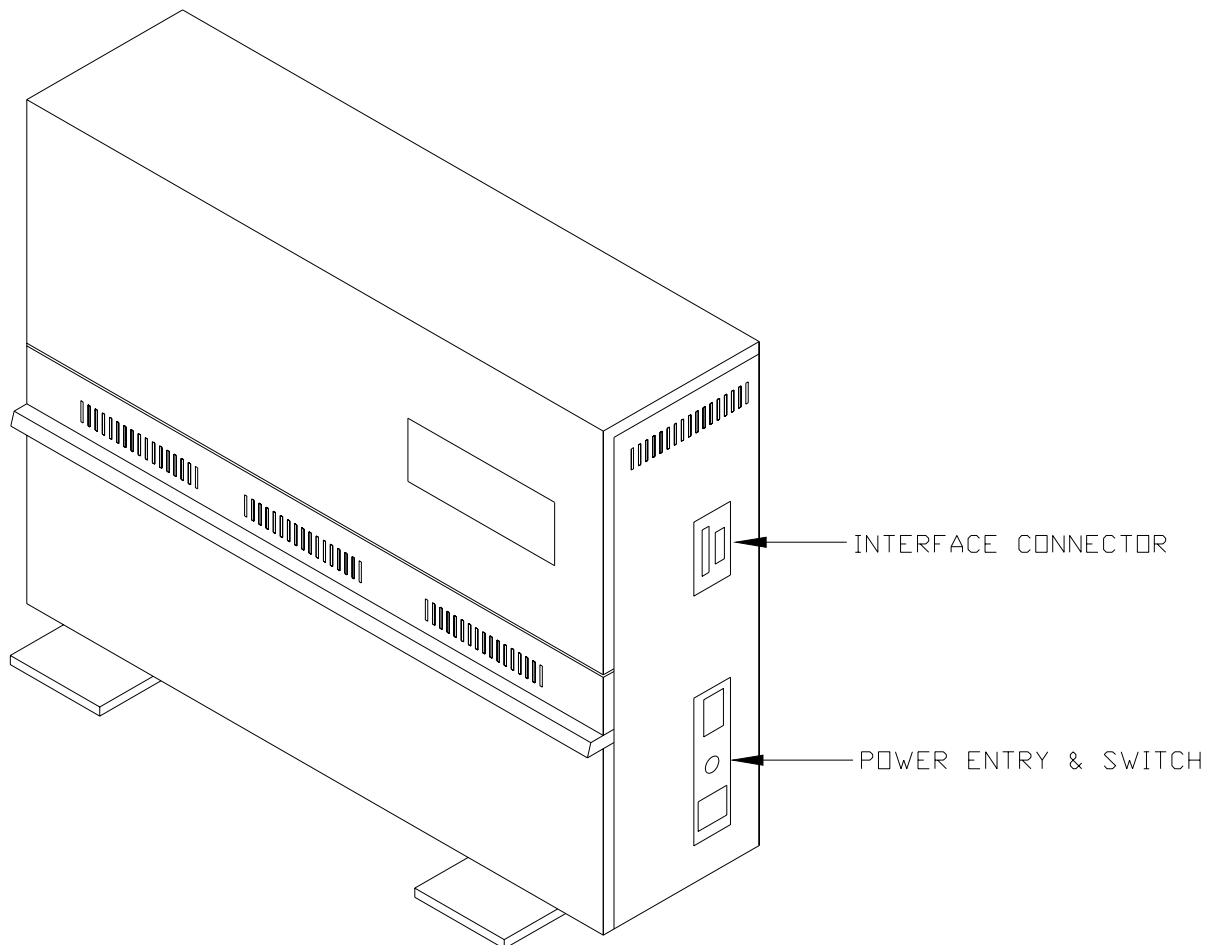

## 1.2 Product Overview

The Model 1200R plotter is a direct-thermal type utilizing continuous roll format thermally-sensitive media of 12 inch (305 mm) width. The plotter uses a precision thermal printhead with elements spaced at 1/200 inch (0.127 mm). A variety of different media types are available to meet different user requirements. The plotter-host interface is compatible with Versatec™ standard for printer/plotters.

## 1.3 Media

Good quality media is essential for obtaining acceptable imaging performance. Atlantek maintains a stock of recommended media which will assure top performance, as outlined in Section 9. However, if you do not buy your media from Atlantek, we caution you to specify media with low abrasivity and moisture content to attain maximum printhead life.

The Model 1200R plotter requires media 12 inches (305 mm) wide, wound coated-side-out on a 1 inch (25.4 mm) diameter core.

**Caution:** Use of paper with a high moisture content is to be avoided. This can be determined if during plot/print, there is noticeable moisture condensed out on the media cut shelf. Such a condition is deleterious to printhead life. Printheads are not warranted against damage due to operation with media with a high moisture content.

## 1.4 Maintenance

The plotter normally should not require any periodic maintenance except for periodic cleaning of the thermal printhead dot line. Information specific to this task is outlined in Section 4.3. This shall be necessary when the plotted output exhibits an insufficient blush characteristic in localized positions. Cleaning of the printhead more often than every 10 rolls of media (500 feet per roll) is a sign that substandard media is in use.

## 1.5 Safety

Personnel installing, operating, and maintaining the plotter should be thoroughly proficient in the installation, operation, maintenance, and service of the plotter. To their safety, and the safety of operator and maintenance personnel, basic precautions follow. These should be reviewed to promote safety awareness.

### General

- Wear safety shoes, glasses, and gloves when uncrating the equipment.
- Wear safety glasses when maintaining or servicing the equipment.
- The equipment is heavy. Use sufficient personnel and/or lifting devices for its movement.
- Beware of sharp edges, pinch points, and exposed staples when uncrating.
- Observe all warnings and cautions, stated or implied, in the procedures.

### Mechanical

- Unless specifically instructed otherwise, do not operate the equipment with covers or access panels removed.
- Keep fingers, hands, and tools clear of moving parts.
- Route cables properly to eliminate tripping hazards.

### Electrical

- When disconnecting the power cord, tag the prongs of the plug to prevent anyone from restoring the electrical power.
- Do not defeat or bypass built-in equipment safety features.
- Replace electrical components with units of equal rating and capacity.
- If any panel, cover, or guard must be removed for a given electrical adjustment or check, extreme caution shall be exercised to prevent personal injury. Wear insulated gloves when access to energized electrical components becomes necessary.

## 2. Specifications

Package Configuration.....	Table Top, paper exits in front of unit Available with optional Wall Mount Bracket
Dimensions .....	Height: 24.8 inch (63 cm) Width: 19.4 inch (49 cm) Depth: 9.4 inch (24 cm)
Weight.....	60 lbs (27 kg)
Environmental	
Operating Temperature.....	0 to +50°C
Operating Humidity.....	20 to 90% R.H. (non-condensing)
Storage Temperature.....	-20 to +70°C
Storage Humidity.....	5 to 90% R.H. (non-condensing)
AC Power	
Operating Voltage.....	User Configurable 100 to 120 VAC, 50/60 Hz or 198 to 242 VAC, 50/60 Hz
Power consumption.....	750 W, 6.2A max running @ 115 VAC 180 W, max idle load
Data Interface.....	Versatec™-compatible parallel, 2 User Configurable Modes: Differential mode to 300 ft (91.4 m) TTL mode to 25 ft (7.6 m)
Output speed	
Plot.....	5.0 inch/sec, max (292 bytes, Energy Lev 1)
Print.....	2.2 inch/sec, max (146 chars, Energy Lev 1)
Resolution (Plot Mode).....	200 dot/in, 292 bytes (2336 pixels), max width
Active plot/print span.....	11.68 inch (296.6 mm)
Image dithering.....	5 possible positions; total dither span ranges over 0.16 inch (4.1 mm). May be disabled by user under front panel menu control.
Front Panel Controls.....	On/Off-Line, Media Feed, Self Test Plot/Print, Media Count Reset, Configuration and Status Polling
Front Panel Indicators.....	LED Lamps: Power, On-Line, Low Temperature, High Temperature, Alarm Liquid Crystal Display, 16 character; for Media Count and Configuration
Recommended media.....	Thermal Sensitive Paper or Synthetic 12 in (30.5 cm) wide, 1in (2.5 cm) i.d. core Wound coated side out See Section 9 for information
Accessories.....	Audible Out-of-Paper Alarm Wall Mount Bracket
	Atlantek Part No. 500239 500334-1

### 3. Installation

#### 3.0 General

The general procedure for installing the equipment consists of unpacking, inspecting, moving, installing and checking. The instructions and safety recommendations set forth in Section 1 constitute a prerequisite to these instructions.

**Note:** For basic installation and troubleshooting, it is necessary to locate and distinguish the two major pc boards in the plotter.

In the Model 1200R, this may be done from the front of the plotter with the front/top cover panel removed. Both boards are mounted on sliding card guides.

- The **Controller Board** is the smaller of the boards and is fully visible.
- The **Processor Board** is the larger of the boards, and is hidden in part by the Controller Board.

#### 3.1 Receiving Inspection

The plotter was carefully inspected and tested prior to shipment. Upon its arrival, inspect the crate or carton for damage. Unpack the plotter as soon as possible and conduct a thorough examination of the unit and its components. Do this in the present of the carrier if at all possible. If damage is noted, take photographs of the damaged portions and immediately file a claim with the carrier. If the carrier is not notified within 15 days of delivery, it cannot be held responsible.

Before placing the plotter into service, note the following items which are secured for shipment:

- The printhead lift lever, located at the extreme right-hand edge of the media roll compartment, is secured for shipment with a "tie-wrap" around the casting which supports the right-hand end of the media roll. This should be cut free for the lift mechanism to function normally.

Consult the following Sections 3.2 through 3.4 for requirements to be considered before operating the plotter. Section 4 should be followed for basic operator information prior to placing the plotter into service.

The plotter may be wall mounted with a convenient wall-mount adaptor plate. The four horizontal slots in the plate may be attached to standard wall studs with centers spaced 16 to 24 inch (41 to 61 cm) apart. Use lag screws of ¼ inch (6 mm approx) diameter, 1½ inch (38 mm approx) minimum length.

**Warning:** The plotter with a full roll of media weighs approximately 124 lbs (57 kg). Make sure the wall mounting plate is adequately fastened to the wall.

### 3.2 Line Power Input Requirements

This equipment is provided with moveable voltage selector jumpers at one of the two AC-to-DC power supplies to allow use with incoming line voltages in the range of 100-120 or 198-242 V AC, single phase, 48 to 62 Hz. If the electrical power supply (as measured during normal operation of the equipment) falls outside these ranges, a voltage correcting transformer must be used. The line voltage configuration as shipped is 100-120 VAC, unless the plotter is externally tagged otherwise.

**Caution:** The electrical installation should conform to the codes and requirements of the country or locality in which the equipment is to be installed. The power outlet must be installed near the equipment and be easily accessible. Check for adequate capacity in the line service when choosing the site for the plotter installation. See Specifications for maximum electrical load characteristics. The line service should be properly grounded to insure operator safety.

The plotter is supplied with a 6 foot (183 cm) appliance line cord with a plug suitable for use in North America for 115 VAC operation. Similar cords are available for use in other countries.

For the safety of service personnel, observe sensible practices to insure that line power is not inadvertently applied to a plotter while the case or rear panel is removed for service or inspection procedures.

### 3.3 Line Voltage Selection

The power supply for generation of print and motor drive voltage has specific strapping requirements which must be followed according to the line voltage range. This component is located in the top left-hand side of the plotter chassis, above the thermal printhead. They may easily be observed with the front/top cover panel removed. Section 10.4 gives specific instructions for configuring both power supplies. The logic power supply is designed for the full range of line voltage without strapping.

**Caution:** Be certain that the voltage selector jumpers for the Print Power Supply is set properly before connecting electrical power.

### **3.4 Data Interface Configuration**

The plotter data input is Versatec™ parallel-format compatible and can be configured for either single ended (TTL compatible) or differential (long line) data interfaces. Configuration is accomplished by the position of a jumper plug or switch on the Processor Board, together with the choice of connector on the Processor which is to receive the interface cable from the external 37-pin data connector to which the user host system connects. To do this, the plotter front/top cover must be removed (see Section 10.1). This change is fully described in Section 5.1 and Figure 5.

Unless otherwise specified at the time of order, the plotter is shipped from the factory configured for the differential data interface. A standard Versatec™ data interface cable may be used to connect the plotter to the host system. Refer to this table when assembling or testing a data cable. A complete description of the parallel data interface is given in Section 5 - Data Interface.

## 4. Basic Operation and Controls

This section describes the user-accessible controls and indicators used on the plotter and describes basic operating procedures. It is recommended that operator read this section in its entirety before performing any procedure.

### 4.1 Printhead Lift Mechanism

In order to facilitate media loading, a printhead lift mechanism is implemented which can be actuated by the operator. The lift lever can be easily seen at the extreme right-hand edge of the mechanism, in the opening in the front of the plotter case. Simply pull this lever out and upwards to unlock the printhead and lift it into an upwards position, useful for media loading or head cleaning should this be necessary. When it is desired to restore the printhead to its operational position, push the lever downwards and in until the detent is felt.

### 4.2 Loading Media (refer to Figure 2)

**Note:** Media loading may be performed with power On or Off.

**Figure 2 -- Media Threading Path (right-hand side view)**

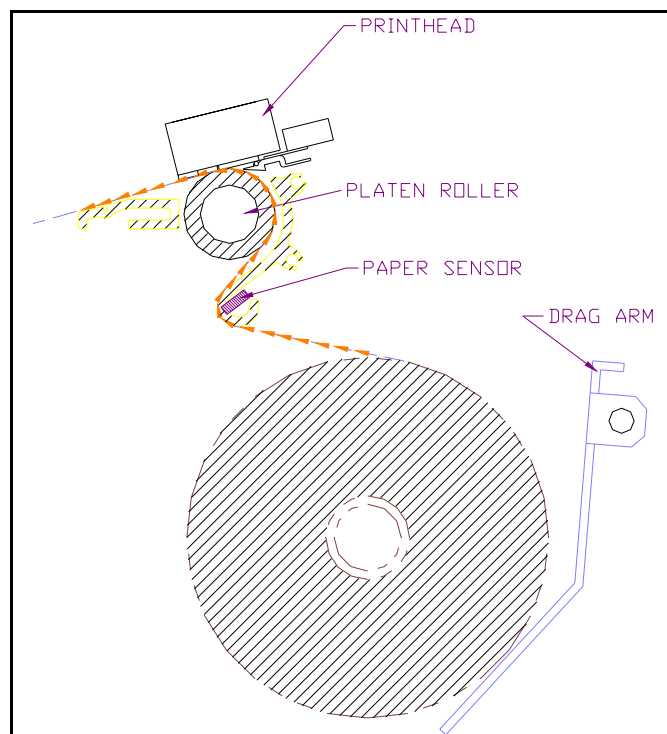

1. Identify and install the correct thermal media. The right-hand media core plug is spring loaded. The media roll should be loaded onto this end first. Some units may have a retractable core plug assembly on the left-hand side. If this is the case, the core plug should be retracted first by moving the core plug lever up and to the left.
2. Orient the media roll so that the loose end comes off the top of the roll. Insert the right-hand end of the media core onto and against the spring-loaded right-hand core plug.

- 3a. On units with a retractable left-hand core plug assembly, swing in the left-hand end of the media roll, align the core with the core plug, slide the core plug to the right, and lock the lever by moving it down in its track.
- 3b. On units with a fixed left-hand core plug assembly, push the media to the right against the right-hand core plug and position the left-hand end of the media core in alignment with the core plug. Spring pressure will assist the roll to the left and onto the left-hand core plug.
4. Once the media roll has been installed, take a moment to observe the function of the media drag arm underneath the media roll. The mohair pad of this drag arm should be riding on the roll.
5. In order to thread the media through the plotter mechanism, first lift the printhead by pulling out-and-up on the printhead lift lever at the right-hand edge of the plotter mechanism. In addition, it is helpful to snap out the black media cutting shelf in front of the drive platen. If the media web free end is ragged, it is recommended that the operator cut it off cleanly for ease of threading.
6. Grasp the media web free end at the sides with the coated (outside of roll) surface down and the end facing away from the operator. Insert the free end into the slot below the rubber drive platen and above the gold-colored guide bar into the guide chute. While inserting the web, watch for the end to emerge from the plotter on the top surface of the platen, in the slot between the platen and the plotter case. It is sometimes helpful to laterally shift the web while inserting it or to insert at a slight oblique angle. If the plotter is operational, it may facilitate threading to trigger platen rotation by momentarily pressing the **PAPER FEED** key, as described in Section 6.4.2.
7. When the free end has emerged above the platen, grasp it and pull it through approximately 1 to 2 ft (30 to 60 cm). Draw the web down to the supply roll and attempt to align the edges of the outfeed portion of the web laterally with the supply roll.
8. If the web is not square through the mechanism, it can be shifted to achieve this by momentarily relaxing manual tension on the web and then centering the web with a quick pull laterally near the platen.
9. Lock the printhead down by pushing the Printhead Lift Lever down-and-in until a detent is felt. Wind the supply roll backwards to take up loose media between the roll and the platen roller. Check that the media rides tightly and with minimal wrinkles against the guide bar under the platen roller. This is important because excessive wrinkles can cause inadvertent tripping of the Media-Out Sensor, which is located in the forward-facing surface of the guide bar. It may be necessary to repeat Step 8 until the media is square through the mechanism.
10. Close the door to the media compartment

### 4.3 Printhead Cleaning

The printhead does not require frequent cleaning with normal usage. Occasionally deposits may build up on the printhead which hinders effective heat transfer to the thermal media, and can result in poorly defined images. This is usually a sign of low-grade media in use.

Should it become necessary to clean the printhead, open the front door and raise the printhead using the printhead lift lever. The thermal elements are approximately 0.6 inch (15 mm) back from the edge of the printhead carrier block. Use a cotton cloth gauze or clean rag (make sure there are no metal fragments on it!) soaked in isopropyl alcohol. Work the cloth in sufficiently to bear upon the thermal elements and then wipe the printhead laterally while applying upward pressure. Difficult cases may require persistent cleaning action.

For very stubborn deposits, 3M Wetordry™ Model 3M 281Q polishing paper (US Mesh: 6000) is a durable material which may be used with isopropyl alcohol to enhance cleaning action.

If it is found to be necessary, wrap the cleaning material around the end of the wooden cleaning stick provided with the plotter or equivalent implement. This may be of assistance in scrubbing of the dot line. *It is not necessary to insert the stick any more than 1 inch (2.5 cm) beyond the cover lower edge in order to bear upon the dot line.*

Note: The recommended cleaning stick is an ordinary tongue-depressor, 1/16 inch (1.6 mm) minimum thickness, available through most pharmacies or medical equipment suppliers.

**Caution:** The thermal printhead is a fragile ceramic substrate containing active electronic circuits. Use extreme care to avoid damage when cleaning or servicing. Never use metal objects to clean the printhead dot line, as it can be easily damaged by this. Do not insert any implement thinner than 1/16 inch (1.6 mm) between the printhead and platen as this may damage circuitry along the bottom surface of the printhead. The warranty does not cover printheads damaged by misuse.

After cleaning, allow 1 to 2 minutes for the alcohol to dry before reloading media.

### 4.4 Front Panel Indicators and Controls

This section describes the function of front panel indicators, display, and keys in the basic Online and Offline operational states. A detailed discussion of these features as they relate to all operational states is given in Section 6 -- Operational States.

**Figure 3 -- Front Control Panel Layout**

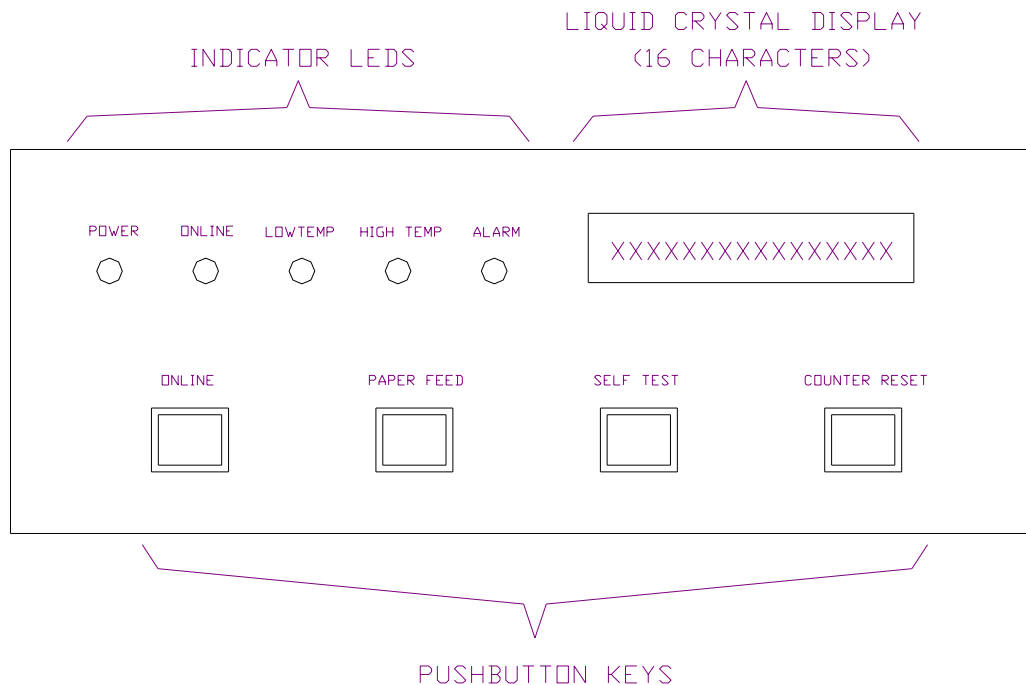

#### 4.4.1 Pushbutton Keys

- **ONLINE** -- Pushbutton key that toggles the unit's status between Online and Offline. Online state activates the plotter data interface and disables PAPER FEED and SELF TEST controls. Offline state disables the plotter data interface and enables these controls.
- **PAPER FEED** -- Pushbutton key that, when pressed and held, produces continuous media feed until released. Alternatively, a momentary key press produces a Form Feed equivalent media advance. This function operates only when the plotter is Offline
- **SELF TEST** -- Pushbutton key that upon momentary press, triggers output of the configured Test pattern. This function operates only when the plotter is Offline. It allows easy user check on plotter functions without requiring connection to a host system.
- **COUNTER RESET** -- Pushbutton key switch that resets the media usage counter displayed on the display to the selected reset value. This could be "0" if Up counting mode is selected, or a preset number (this would normally be set to media roll size in feet) if Down counting mode is selected. When the plotter is Offline, this key is also used to access the Configuration menus.

#### 4.4.2 Alphanumeric Display

This is a 16-character liquid crystal display that normally indicates current status of the Media Usage Count. This report appears as one of the following:

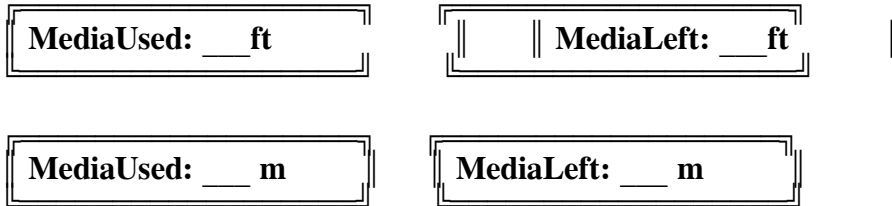

depending on whether the Media Count is configured for the Up or Down-counting modes, respectively (see Section 7.10). The number displayed represents the amount of media used or remaining (assuming correct configuration of the Media Reset Length and proper actuation of the **COUNT RESET** key). The unit of the length display can be either in feet (ft) or meters (m) according to the configured Display Unit (see Section 7.11). The number displayed is updated based upon anticipated chart motion as performed by the chart drive stepper motor. As such it may be misleading if the user manually pulls through or backs up a significant length of chart. The length count as displayed is continually updated into non-volatile memory and so its value is preserved through a power-down period.

#### 4.4.3 Indicator Lamps

- **POWER** -- Green lamp lit indicates presence of +5V logic power.
- **ONLINE** -- Green lamp lit indicates that the plotter is in Online state, suitable for host interface driven operation.
- **LOW TEMP** -- Yellow lamp lights whenever the printhead operating temperature is below the normal range (approximately 40°C), as determined by the thermostatic printhead background temperature controls. This will normally occur only in the first few minutes after power up of the plotter.
- **HIGH TEMP** -- Yellow lamp lights whenever the printhead operating temperature approaches the upper limit of the normal safe operating range (approximately 60°C), as determined by the thermostatic printhead background temperature controls. This will normally occur only under conditions of exceptionally heavy and fast plotting. From approximately 52°C and above, this lamp shall flash, thus indicating that the print/plot speed is being limited on account of temperature. As the printhead temperature rises further, the flash rate shall increase, and output speed limited further. This technique is employed to limit printhead temperature rise such that no interruption of plotting shall be encountered. However, if temperature nonetheless rises to the upper limit, the print/plot output shall be blanked, and the lamp shall indicate this by being On constantly for the duration of this condition.
- **ALARM** -- Yellow lamp lights when any condition is sensed that prevents normal operation and could require corrective action by the operator. Usually this would result from a mechanical fault detected through one of the sensors. The alarm is explained on the display.

#### 4.5 Side Panel Functions (refer to Figure 4)

- **Power On/Off Switch** -- Two position rocker switch that applies AC power to the power supplies. The position marked with a "0" indicates the Off state. The position marked with a "|" indicates the On state.
- **Fuse** -- Fuse in series with the AC input wiring to both power supplies. In the event that replacement is needed, use a 10 A slow-blow fuse for 115 V AC operation or a 5 A slow-blow fuse for 230 V AC operation.
- **Line Power Connector** -- IEC-type line input connector. Attach the proper line cord for intended installation.
- **Data Input Connector** -- A 37-pin D connector used for the parallel data interface. A standard Versatec™ cable may be used here. Table 1 details the pin assignments.

**Figure 4** -- Right-Hand Side Panel Layout

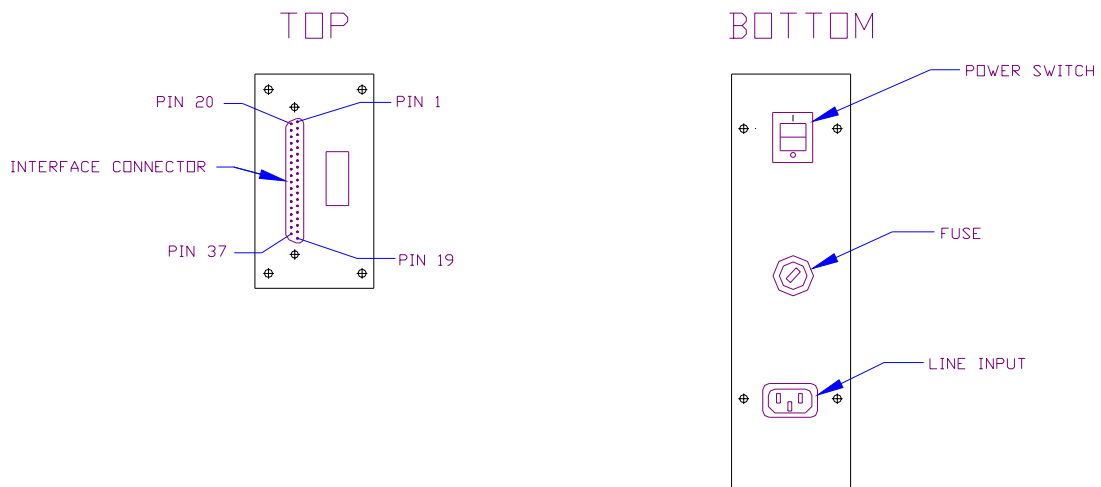

## 4.6 Protective Sensors and Operator Interaction

The plotter is equipped with optical sensors that serve to protect the internal components and to provide useful prompts to the user when the plotter is not in an operable condition. The function of these may have impact on everyday usage of the plotter.

### 4.6.1 Printhead Lift Sensor

As outlined above, the plotter is equipped with a printhead lift mechanism, activated manually by the lever at the right side of the mechanism. The printhead must be engaged in the print position whenever the printhead is activated. This prevents damage to the printhead from improper heat sinking of the dot elements when energized in free air.

To insure that the printhead is properly engaged, a flag mounted to the pivot arm of the printhead lift lever interrupts the light beam of a gap-interrupt type optical sensor mounted to the right printhead support strut. As soon as the printhead moves out of the fully engaged position, the flag moves out of the sensor gap, and print/plot and media advance are disabled. The **ALARM** lamp shall light, and the front panel display shall indicate:

**Printhead Lifted**

In order to restore the plotter to an operational condition, simply push the printhead lift lever downwards and in until the detent is felt. The alarm should then clear, and the plotter shall be in the Offline State. The plotter can then be placed Online if desired using the **ONLINE** front panel key.

### 4.6.2 Media-Out Sensor

A media-out sensor is provided to protect the printhead and mechanism from unnecessary wear and to alert the operator in the event that media is consumed. This sensor is an infrared reflective LED device and is mounted behind the front surface of the extruded media guide chute, as illustrated in Figure 2. The sensor is directed outward such that it detects the presence of media as it wraps around the front part of the extruded chute. When this reflective surface is lost, as happens when media is consumed, print/plot and media advance are disabled. The **ALARM** lamp shall light, and the front panel display shall indicate:

**Out of Media**

Naturally, this condition shall be encountered should the plotter be powered up with no media installed. No harm can result from this. In order to restore the plotter to an operational condition, make sure the printhead is lifted, and install the media. When the media-out sensor detects an adequate reflective surface, the display shall change to:

**Printhead Lifted**

Then simply lock the printhead down. The alarm should then clear, and the plotter shall be in the Offline State. The plotter can then be placed Online if desired using the **ONLINE** front panel key.

The user could encounter a problem with the use of transparent or translucent films in that there may be insufficient reflectance from these to register as a valid media-present condition. If this is the case, the User may mask Media Sensing using the "Media Sense Enable/Disable" control available in the User Configuration Menu (see Section 7.4). Alternatively, as a quick expedient, the user can apply a white adhesive paper label over the sensor viewing port.

In the case that Media Sensing is Disabled, the Stall Sense in effect functions to stop the plotter when media runs out, in which case Stall Sensing (see Section 10.1) should never be disabled.

#### 4.6.3 Platen Rotation Sensor

This optical sensor is used to detect platen rotation stall and to disable normal operation in the event of a belt breakage or a mechanical jam, or motor drive failure. This is accomplished by a chain sprocket mounted to the left side of the platen roller that serves to interrupt the sensor beam as it rotates. The internal electronics compares motor step pulses with sensor-determined rotation of the platen. If the relationship between motor steps and platen rotation changes beyond an acceptable error range, print/plot and media advance are disabled. The **ALARM** lamp shall light, and the front panel display shall indicate:

**Mechanism Stall**

Whenever this condition occurs, inspect the unit and, if possible, cure the cause of the alarm. Lifting the printhead shall then cause the display to change to:

**Printhead Lifted**

In order to restore the plotter to an operational condition, simply push the printhead lift lever downwards and in until the detent is felt. The alarm should then clear, and the plotter shall be in the Offline State. The plotter can then be placed Online if desired using the **ONLINE** front panel key.

In the event of a belt breakage, motor drive failure, or other problem that is not immediately remediable, contact the factory or authorized service agent for assistance.

Actions of the plotter in the event of these conditions is further explained in the upcoming discussion of the "Fault Handler" operational state.

## 4.7 Initial Power-Up

After the proper media has been loaded, apply AC power by setting the power switch to the On (|) position.

The Front panel **POWER** indicator should illuminate to indicate that power has been applied. At this time, the **LOW TEMP**, **HIGH TEMP**, and **ALARM** indicators should come on as the unit initializes. The initialization process takes approximately 15 seconds and allows the machine to perform a internal diagnostics, including a test of the sensors. Various messages are reported on the display during this period. The sensor test is indicated by the stepper motor jogging the media forward slightly to check the media transport sensor.

Once initialized, the unit will normally enter the Online state (**ONLINE** indicator on) and the **ALARM** indicator should go off. The **LOW TEMP** indicator will stay on if the plotter has been idle for some time. Take the unit to Offline state (**ONLINE** indicator off) by pressing and releasing the **ONLINE** pushbutton. Press the front panel **PAPER FEED** pushbutton to verify normal media feed.

After the media feed function has been verified, press and release the **SELF TEST** pushbutton. Check the self-test printout to be sure the self-test pattern prints properly. The self-test pattern will be one the available patterns outlined in Section 7.2 -- Test Pattern Selection. The default test pattern is the "Zigzag", and this pattern should appear upon actuation of Self Test until the plotter is configured differently by the user. This pattern verifies proper internal data manipulation and print consistency.

Connect the data interface to the plotter via the data connector on the right side of the unit. Press and release the front panel **ONLINE** pushbutton to put the unit back to Online state. Online state is confirmed by the illuminated **ONLINE** indicator.

Use a Versatec™ compatible data source to drive the plotter and verify normal operation. If the plotter has been Off for long at normal room temperatures, the **LOW TEMP** indicator will remain illuminated for 10 to 15 minutes after initial power-up. This indicates that the printhead is not fully up to operating temperature. Plots run during this time may be slightly lighter than normal.

## 5. Data Interface

The following information is intended for system integrator, programmers, installers, and service personnel to assist in configuring the host system used with the plotter.

### 5.0 General

The plotter is a 200 dot/inch (8 dot/mm, approx.) unit capable of plotting up to 5.0 inches per second (127 mm per second) in a plot (raster data) mode. The plotter can operate as either a plotter or, using the internal character generator, as a printer. In the plot mode it has a width capacity of 292 bytes (2336 pixels).

The interface to the plotter is designed to be compatible with the Versatec™ parallel interface, as defined in Electrostatic Printer/Plotter Interface Specification, Bulletin Number 312, September, 1977. Clarifications and/or modification to this specification are contained in V80 Series Electrostatic Printer/Plotter Specification. Bulletin Number 476, December, 1979.

The plotter data interface supports both the plot-only and print-only Versatec™ compatible data interface modes. The simultaneous print/plot mode, as defined by the Versatec™ interface specifications, is not currently supported by the plotter.

### 5.1 Parallel Interface Signals

The plotter connects to a host system via a 37-pin D connector. The connector mounted on the plotter has pin contacts (DB-37P). The electrical interface is factory set for differential (long lines) configuration, but may be configured for TTL (single ended). Selection is done by connecting the internal ribbon cable from the D connector to the appropriate connector on the Processor Board and by application of the three pin jumper plug in the appropriate position as illustrated in Figure 5. Some versions of the Processor Board may be equipped with a slide switch in the location of the jumper with the positions labelled "**DIF**" and "**TTL**". To examine and/or change this, the plotter front/top cover must first be removed (see Section 10.2).

**Figure 5 -- Data Interface Configurations**

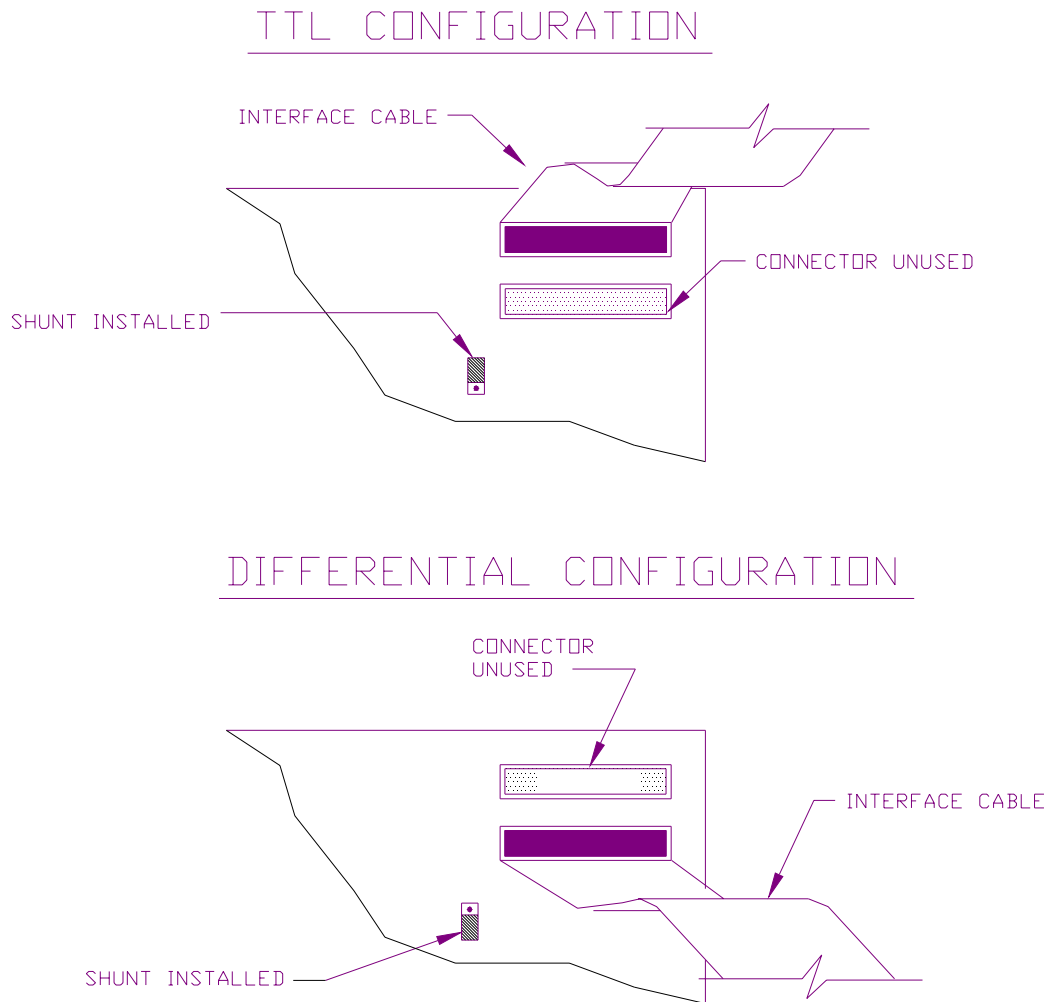

**Important:** To insure proper interface function, both the ribbon cable between the panel-mounted interface connector and the Processor Board and the jumper plug (or slide switch if so equipped) on the Processor Board must be set properly according to the desired interface format.

Table 1 lists the pins of interface connector with the signal names for both the TTL and differential interfaces. Table 2 lists the signals and gives a functional description of each. The plotter interface consists of eight data lines, one print/plot mode select line, six command lines, and two status output lines. In the case of the TTL-compatible format, each signal is communicated by one physical line, all being referenced to digital ground. In the case of differential format, each signal is communicated by an active high/low line pair. The digital ground connection over the interface cable in this case is not required, but is provided at the connector. Usually this connection (shown as **DGND** in Table 1) will be in parallel with the equipment safety earth-ground connections.

**Table 1 -- Interface Connector Pin Assignment**

D Conn'tr Pin Number	Signal Mnemonic			
	TTL		Differential	
1	IN1		IN1+	
20		DGND		IN1-
2	IN2		IN2+	
21		DGND		IN2-
3	IN3		IN3+	
22		DGND		IN3-
4	IN4		IN4+	
23		DGND		IN4-
5	IN5		IN5+	
24		DGND		IN5-
6	IN6		IN6+	
25		DGND		IN6-
7	IN7		IN7+	
26		DGND		IN7-
8	IN8		IN8+	
27		DGND		IN8-
9	CLEAR.L		CLEAR-	
28		DGND		CLEAR+
10	PICLK.H		PICLK+	
29		DGND		PICLK-
11	READY.L		READY-	
30		DGND		READY+
12	PRINT.H		PRINT+	
31		DGND		PRINT-
13	reserved		DGND ** Note 1 **	
32	** Note2 ** INOP.H			INOP-
14	reserved		reserved	
33		DGND		reserved
15	RESET.L		RESET-	
34		DGND		RESET+
16	RFFED.L		RFFED-	
35		DGND		RFFED+
17	REOTR.L		REOTR-	
36		DGND		RESET+
18	RLTER.L		RLTER-	
37		DGND		REOTR+
19	INOP.H ** Note 2 **		INOP+	

Notes:

- "DGND" is logic common "ground". It is internally connected to the plotter frame and from there to the AC power earth ground terminal on the power input connection.
- (Differential interface only)** Pin 13 is available for joining Digital Ground between plotter and host. If this is not desired, the connection can be broken by removing Jumper Shunt JP4 on the plotter Processor PC Board Assembly.
- (TTL interface only)** These pins carry identical INOP.H (Low=Online, High=Offline) status outputs. According to the published Versatec™ TTL interface specs, Pin 32 is expected to be an "ONLINE.L" output, and Pin 19 is expected to be a "NOPAPER.H" output. For installations which follow this, a direct connection should yield acceptable results.

The differential format is always preferred for reliable host-plotter interfacing. We advise against employing the TTL interface for cable runs over 25 ft (7.6 m). If the TTL interface must be used, make sure that the interconnecting cable is constructed with each signal wire paired with its adjacent DGND contact in a twisted pair configuration (pin 1 with pin 20, pin 2 with pin 21, etc., up to pin 18 with pin 37; pin 19 need not be paired). This cable construction is also recommended for the differential interface. A continuous cable shield, terminated to the connector metal shells at each end, is also recommended both to reduce EMI emissions and susceptibility to outside interference.

**Table 2 -- Interface Signals and Functions**

Signal	Function	TTL Active Level	Source
IN1	Parallel Input Data (LS Bit)	Plot Polarity True = Black False = White	Host
IN2	Parallel Input Data		
IN3	Parallel Input Data		
IN4	Parallel Input Data		
IN5	Parallel Input Data		
IN6	Parallel Input Data		
IN7	Parallel Input Data		
IN8	Parallel Input Data (MS Bit)		
PICLK	Parallel Input Clock (False-to-True)	High = True	
PRINT	True = Print; False = Plot	High = True	
RLTER	Line terminate command	Low = True	
RFFED	Line term w/ Form Feed command		
REOTR	Line term w/ EOT command		
CLEAR	Line term w/ Buffer Clear		
RESET	Interface Reset		
READY	True = Ready to receive byte	Low = True	Plotter
INOP	True = Offline; False = Online	High = True	

The interface signal functions are as follows:

- **IN1** through **IN8** contain the data to be printed or plotted. These lines are monitored by the plotter with every **PICLK**. The data line should be changed only when **PICLK** is false.
- **PICLK**, when true, indicated that a byte of data is ready for transmission to the plotter. This line should go true only when **READY** is true and **INOP** is false; otherwise, it will be ignored. When the **PICLK** signal has been accepted by the plotter, **READY** will go false to signal the host to remove **PICLK** and the data.
- **PRINT** when true, indicates that the print mode of operation is selected; when false, it indicated that plot mode is selected. This signal is monitored by the plotter with every command signal. **PRINT** should be changed only when **PICLK** and the remote commands are false.
- **RLTER**, when true, indicates that any data in the print or plot buffer is complete and is to be printed/plotted, with accompanying normal chart advance (ie. no extra feed) for that plot or print line. This line should go true only when **READY** is true and **INOP** is false; otherwise, it will be ignored. When the **RLTER** has been accepted by the plotter, **READY** will go false (ie. busy) indicating the host should remove **RLTER**.

- **RFFED**, when true, indicates that any data in the print or plot buffer is complete and is to be printed/plotted, after which the media is to be advanced in accordance with the Form Feed function, as configured. Response to Form Feed is outlined in Section 7.13 -- Form Feed Length. Default action is to feed 2.5 inch (63 mm, approx.) of chart. This line should go true only when **READY** is true and **INOP** is false; otherwise, it will be ignored. When the **RFFED** has been accepted by the plotter, **READY** will go false (ie. Busy) indicating the host should remove **RFFED**.
- **REOTR**, when true, indicates that any data in the print or plot buffer is complete and is to be printed/plotted, after which the media is to be advanced in accordance with the End of Transmission Advance function, as configured. Response to this is outlined in Section 7.14 -- End of Transmission Advance Length. Default action is to feed 8.0 inch (203 mm, approx.) of chart. This line should go true only when **READY** is true and **INOP** is false; otherwise, it will be ignored. When the **REOTR** has been accepted by the plotter, **READY** will go false (ie. busy) indicating the host should remove **REOTR**.
- **CLEAR**, when true, indicates that any data in the print or plot buffer is to be cleared. Any partial data lines which have been received but yet to be plotted/printed are lost. This line should go true only when **READY** is true and **INOP** is false; otherwise, it will be ignored. When the **CLEAR** has been accepted by the plotter, **READY** will go false (ie. busy) indicating the host should remove **CLEAR**.
- **RESET**, when true for 100 nsec or more, forces the plotter to reset the interface hardware. Any partial data lines which have been received but yet to be plotted/printed are lost. Function is similar to **CLEAR** except that it is not dependent upon the **READY** signal being asserted in order to be effective. This line is honored by the plotter when in Online state only.
- **READY**, when true, indicates that the plotter is ready to accept a new data byte or command from the host system. **READY** is set false, to indicate that the plotter is busy, approximately 120 nsec after the receipt of a asserted signal from any one of **PICLK**, **RLTER**, **RFFED**, or **REOTR** from the host system. As soon as **READY** goes false, the host system should remove the data or command. **READY** will be brought true after the data or command has been processed and the command from the host has been removed, thus confirming that a new data byte or command may be received. **READY** is also set false at start-up and stays false until all of the internal power-on reset processing is completed and the plotter is in Online state.
- **INOP**, when true, indicates that the plotter is inoperable through the host interface for some reason. This could mean that either the plotter is in Offline state or an Alarm condition exists. If an Alarm exists, the display panel on the plotter should report a message indicating the cause. **INOP** will be brought false after the **ONLINE** key has been toggled to put the plotter to Online state (assuming any problem conditions have been fixed). **INOP** is also set true at start-up and stays true until all of the internal power-on reset processing is completed.

## 5.2 Handshake Protocol

The plotter interface uses a simple software handshake protocol. Whenever READY is true, the host system is allowed to assert a command signal (one of PICLK, RLTER, RFFED, CLEAR, or REOTR). After a settling delay of approximately 120 nsec, the command is accepted and READY is negated. When the host system has detected READY going false, it responds by negating the command. After the internal processing is complete, the interface logic re-examines the command signals and asserts READY, if and when they are all negated. If the host system either fails to negate the command or negates it and re-asserts another command before the READY has been re-asserted, the interface will stay busy forever. The timing diagram in Figure 6 illustrates the interaction of the various command and status lines.

Only one command signal should be activated at a time, otherwise the interface may arbitrarily process one and ignore the other. RESET will override any other command signal and will be accepted whenever the plotter is in Online state.

Remote command lines RLTER, RFFED, REOTR, and CLEAR are polled upon the completion of their assigned functions. If the command signal has not been negated as of this time (10  $\mu$ sec, min, after the negation of READY in response to the command), then an internal trap shall be actuated and an alarm message of the form:

**Halt: Intfc** \_\_\_\_\_

shall be displayed on the front panel. The " \_\_\_\_\_ " field shall indicate the command line effected. The plotter must be power cycled to resume normal function. The most probable cause of this is a faulty host interface system or interconnecting cable. Possibly, this may result from failure of the host driver hardware to initialize promptly with all command signals to the plotter in a negated state.



Plot line termination occurs upon:

- Full Buffer (number of bytes depending upon the configured Plot Width and Resolution)
- RLTER line assertion
- RFFED line assertion
- REOTR line assertion
- Mode change from plot mode to print mode (recognized upon PICLK assertion)

### 5.2.2 Print Mode

When used in print mode, the plotter accepts 8-bit data bytes encoded in ASCII and converts them via an internal character generator into successive raster lines. The characters first appear as upside-down, and the print line will fill from right to left as media exits. This is proper as it results in readable text, when the chart is turned for viewing. This character set is described in Section 5.3 -- Internal Character Set.

The PICLK signal clocks successive bytes of data into the print buffer when the PRINT mode line is true. After the buffer is filled up (number of bytes depending upon the configured Print Width), the buffer is automatically formatted and printed. Subsequent PICLK's will place data onto the next print line. Partially full print buffers can be forced to be printed by using one of the remote commands or by embedding either the ASCII Carriage Return (CR, 0D<sub>hex</sub>), Line Feed (LF, 0A<sub>hex</sub>), Form Feed (FF, 0C<sub>hex</sub>), or End of Transmission (EOT, 04<sub>hex</sub>) characters into the data stream. The CR and LF are treated the same as the remote line terminate, RLTER, command. The first CR or LF after an automatic Full Buffer line terminate is ignored. A mode change will also cause a partially full print buffer to be printed (refer to "Mode Changes" for more information).

Print line termination occurs upon:

- Full Buffer (number of bytes depending upon the configured Print Width)
- ASCII CR (0D<sub>hex</sub>) (handled same as RLTER)
- ASCII LF (0A<sub>hex</sub>) (handled same as RLTER)
- ASCII FF (0C<sub>hex</sub>) (handled same as RFFED)
- ASCII EOT (04<sub>hex</sub>) (handled same as REOTR)
- RLTER line assertion
- RFFED line assertion
- REOTR line assertion
- Mode change from print mode to plot mode (recognized upon PICLK assertion)

### 5.2.3 Plot/Print Mode Changes

The current plot or print mode of the plotter is selected by setting the PRINT line true or false, prior to issuing a PICLK or remote command. In normal operation, the PRINT line would be set to the desired state and left there for the duration of the operation.

Since the PRINT line can be changed prior to either a PICLK or a remote command, the processing of a mode change is dependent on the sequence of commands.

**Case 1:** If there is a partially full buffer and a mode change is recognized by a PICLK, then:

- A. The contents of the buffer are printed or plotted as per the prior state;
- B. The new mode is entered; and
- C. The data byte that was coincident with the mode change is the first data for the new mode.

**Case 2:** If there is a partially full buffer and a mode change is recognized by a remote command, then:

- A. The contents of the buffer are printed or plotted as per the prior state;
- B. The command is executed; and
- C. The new mode is entered.

**Case 3:** If the data buffer is empty and a mode change is recognized by a PICLK, then:

- A. If the new mode is entered; and
- B. The data byte that was coincident with the mode change is the first data for the new mode.

**Case 4:** If the data buffer is empty and a mode change is recognized by a remote command, then:

- A. The command is executed; and
- B. The new mode is entered.

### 5.3 Internal Character Set

The internal ROM-based font for printing characters is stored and printed at full 200 dot/inch (8 dot/mm, approx.) resolution. In the defined font, the character cell is (width x height) 16 x 20 dots or 0.080 inch (2.03 mm) by 0.100 inch (2.54 mm). This cell includes both the intercharacter and interline spacing.

The normal printable characters corresponding to codes  $20_{\text{hex}}$  to  $7F_{\text{hex}}$  are supported. These are shown in Table 3. Codes  $80_{\text{hex}}$  to  $FF_{\text{hex}}$  generate the same responses as the analogous code with  $80_{\text{hex}}$  subtracted; with the exception of the control codes (CR, LF, FF, EOT), which only respond with the most significant data bit (IN8) = 0.

**Table 3 -- Internal Character Set and Code Assignment**

00		10		20		30	0	40	@	50	P	60	`	70	p
01		11		21	!	31	1	41	A	51	Q	61	a	71	q
02		12		22	"	32	2	42	B	52	R	62	b	72	r
03		13		23	#	33	3	43	C	53	S	63	c	73	s
04	EOT	14		24	\$	34	4	44	D	54	T	64	d	74	t
05		15		25	%	35	5	45	E	55	U	65	e	75	u
06		16		26	&	36	6	46	F	56	V	66	f	76	v
07		17		27	'	37	7	47	G	57	W	67	g	77	w
08		18		28	(	38	8	48	H	58	X	68	h	78	x
09		19		29	)	39	9	49	I	59	Y	69	i	79	y
0A	LF	1A		2A	*	3A	:	4A	J	5A	Z	6A	j	7A	z
0B		1B		2B	+	3B	;	4B	K	5B	[	6B	k	7B	{
0C	FF	1C		2C	,	3C	<	4C	L	5C	\	6C	l	7C	
0D	CR	1D		2D	-	3D	=	4D	M	5D	]	6D	m	7D	}
0E		1E		2E	.	3E	>	4E	N	5E	^	6E	n	7E	~
0F		1F		2F	/	3F	?	4F	O	5F	_	6F	o	7F	DEL

Notes:

1. All character codes in hexadecimal.
2. Shaded boxes denote control characters with defined line termination functions. See text for functions.
3. All blank box codes print as a space.
4. Character designated as **DEL** indicates a 50% shade-filled cell.
5. Codes 80<sub>hex</sub>-FF<sub>hex</sub> cause same response as Codes 00<sub>hex</sub>-7F<sub>hex</sub>, respectively, with the exception of those corresponding to control codes. These (Codes 84<sub>hex</sub>, 8A<sub>hex</sub>, 8C<sub>hex</sub>, 8D<sub>hex</sub>) print a space.

## 6. Operational States

### 6.0 General

This section describes the range of operational states that the Model 1200R may assume. These are as follows:

- **Initialization** -- entered upon power up
- **Online** -- normal host driven state
- **Offline** -- for media feed and test plotting
- **Alarm** -- sensor-based fault condition detected
- **Configuration** - operator customization of plotter parameters
- **Trap Report** -- internal logical error detected

In the section that follows, each of these operational states is explained in terms of function and user interactions with the keypad and display.

## 6.1 Initialization (Power-Up) State

### 6.1.0 General

In the period immediately following power up, plotter internal electronics performs essential initialization functions, minimal self test, determines the disposition of the previous plotter configuration as stored in nonvolatile RAM (NVRAM), and then determines the appropriate operational state. Several informational messages are output on the front panel display during this period.

One of the first functions of the plotter upon power up is to read the front panel keys. Pressing and holding a key just prior to switching power on can influence actions in the Initialization state. In all cases, the key may be released when the first intelligible message has been posted on the display.

**Table 4 -- Summary for Initialization State**

Indicators	Status	Notes
<b>ONLINE</b>	Off	Interface is inactive (INOP asserted).
<b>ALARM</b>	On	
<b>LOW TEMP</b>	On	Indicators On for verification purposes only, not indicative of actual temperature.
<b>HIGH TEMP</b>	On	
<b>Display</b>	Various messages, refer to text.	
Keys	Function	
<b>ONLINE</b>	Press at power-up, forces Offline state after Initialization.	
<b>PAPER FEED</b>	No function	
<b>SELF TEST</b>	Press at power-up, forces Configuration state after Initialization.	
<b>COUNTER RESET</b>	Press at power-up, forces Flush of all configuration parameters.	

### 6.1.1 Initialization Keypad Functions

Normal action following Initialization is for the plotter to go to the selected default power-up initial state, assuming internal electronics and sensors indicate all is in order. This would normally be Online, unless otherwise commanded.

It may be preferable in a particular environment for the plotter to power-up into the Offline State. This may be useful if the host is in a unknown state for some time following system initialization and it is undesirable for the plotter to respond to possible invalid conditions on the interface. One consequence of this might be for the plotter to feed media continually due to uninitialized outputs from the host. A good way to prevent this is to configure the plotter such that it doesn't go Online, and therefore is doesn't respond to the host. The plotter may be placed Online manually by pressing the **ONLINE** key when the host has been initialized.

If it is desired to stay Offline upon power-up, the user can reconfigure the plotter "Default Power-Up State" (see Section 7.15) for "Offline"; this shall take effect upon the following power-up. Alternatively, the user may press and hold the **ONLINE** key at power up. This results in the plotter going to the state following Initialization contrary to that configured in the Default Power-Up State menu.

Normal action during Initialization is for the plotter to restore the configuration previously in effect. This will not happen if either of two conditions are detected:

- The **COUNT RESET** key is seen as pressed at power up.
- or
- DIP Switch (S2) Station 8 on the Processor Board is On.

Response in either case is for all configurable parameters to be set to known values, a process referred to herein as a "Configuration Flush". This may be useful for a user to return the plotter to a known state in case of persistent trouble. This should be done with caution, however, as all parameters may be affected.

## 6.1.2 Display Functions

During Initialization several reports are issued. These are, in sequence:

- 1.Product model number and software release series

For example:

**Model 1200 -A**

- 2.Processor Board microprocessor software revision number and checksum:

For example:

**PrRv A1.10 6A74**

Note: The Processor Board is one of the 2 major pc boards in the plotter (the Controller Board is the other). Software revision and checksum of both boards can be polled in the Configuration State, Service Menu (see Section 8.2).

- 3.Disposition of internal configuration

One of:

**Confgn Restored** (self explanatory)

**DefCnfg-UserReq** (user requested  
Configuration Flush)

- 4.Internal diagnostic result

For example:

**Error Code: Pass**

If any problem was found in these tests, a 4 hex digit error code number would be displayed in place of "Pass", and this should be reported to Atlantek or its authorized service agent.

At this point, media advance of approximately 0.3 inch (8 mm) should occur while the internal physical sensors (Media Present, Printhead Position, Mechanical Stall) are polled to determine if the plotter is properly configured for operation. If any sensor fault is detected, the Alarm state is entered for display of the problem and prompting of user for correction. If no fault is seen, either Online or Offline state is entered, in accordance with the selected Default Power-Up State and user action at power-up as described earlier.

## 6.2 Online State

### 6.2.0 General

In the Online state, and only in this state, the plotter is sensitive to host input over the parallel port. Specific functions of the parallel port are discussed in Section 5 -- Data Interface. Obviously this state is intended for the vast majority of functional usage of the plotter.

**Table 5 -- Summary for Online State**

Indicators	Status	Notes
<b>ONLINE</b>	On	Interface is active (INOP negated)
<b>ALARM</b>	Off	
<b>LOW TEMP</b>	Off/On	Both Off or one On in accordance with current printhead temperature
<b>HIGH TEMP</b>	Off/On	
<b>Display</b>	Current <b>Media Used</b> or <b>Media Left</b> status	
<b>Keys</b>	<b>Function</b>	
<b>ONLINE</b>	Press to go Offline.	
<b>PAPER FEED</b>	No function	
<b>SELF TEST</b>	No function	
<b>COUNTER RESET</b>	Long press to reset Media Count	

#### 6.2.1 Online State Keypad/Display Functions

When in the Online state, the only keypad functions supported are reset of the media count (using **COUNT RESET** key) and going to Offline state (using **ONLINE** key).

The function of resetting the Media Count is begun by the user pressing the **COUNT RESET** key. The front panel display responds by displaying:

**Hold to ResetCnt**

for approximately 2 seconds. If the **COUNT RESET** key is released before the end of this period, then the display shall be restored to its former length message without changing the Media Count. If the key is held pressed for this period, then at the end of it the display shall change one of the following:

**MediaUsed: \_\_\_ ft**

**MediaLeft: \_\_\_ ft**

**MediaUsed: \_\_\_ m**

**MediaLeft: \_\_\_ m**

The format of the display depends upon the selected modes of media length counting and display units. When the key is released, the actual numeric field (properly reset) is inserted in front of the "ft" or "m" unit label.

Going to Offline state is accomplished by pressing the **ONLINE** key. If plot/print from the host is underway at this time, response to the key press may be slow. Any multi-line functions (ie. character print lines, form feed, etc.) underway when the key press is detected shall finish before the media stops and the keypad request is honored. However, the **ONLINE** indicator does goes Off immediately for the purpose of confirming to the user that the request was detected, and that the key may now be released.

### 6.2.2 Sensor faults

Sensor-fault based alarm conditions (ie. Out of Media, Printhead Lifted, Mechanism Stall) which occur while in the Online state cause immediate stoppage of any plot/print which may be underway and change to the Alarm state.

### 6.2.3 Online State Output Speed

The effective output speed achieved in host-driven Online operation is a product of many factors. Internal logic within the plotter is designed to accept data input from the host and to regulate its output speed up to a prescribed maximum in accordance with the average data transfer rate. Maximum speed is determined by the following:

- Configured Energy Level (see Section 7.1)
- Configured Chart Speed Limit (see Section 7.3)
- Possible slowdown may be enforced by a sensed high temperature condition at the printhead (see Section 4.4.3)
- Constant slow speed may be forced by a DIP switch setting (S3) on the Controller Board. Normally, stations 1-5 would all be in the Off position to enable full speed operation.

Depending upon the host environment and plotter configuration, fluctuating data transfer rates may allow the output plot speed to vary. Section 7.3 discusses the usage of the explicit Chart Speed Limit control if the application requires chart output to proceed at a constant speed.

## 6.3 Offline State

### 6.3.0 General

In the Offline state, front panel based functions Feed and Self Test can be performed, thus serving to verify basic plotter function without connection to a host. The Offline state also serves a means of reaching the Configuration state. All returns out of the Alarm state are to the Offline state.

**Table 6 -- Summary for Offline State**

Indicators	Status	Notes
<b>ONLINE</b>	Off	Interface is inactive (INOP asserted)
<b>ALARM</b>	Off	
<b>LOW TEMP</b>	Off/On	Both Off or one On in accordance with current printhead temperature
<b>HIGH TEMP</b>	Off/On	
<b>Display</b>	Current <b>Media Used</b> or <b>Media Left</b> status	
Keys	Function	
<b>ONLINE</b>	Press to go to Online state	
<b>PAPER FEED</b>	Short press to trigger Form Feed Long press to perform continuous media feed	
<b>SELF TEST</b>	Press to start Self Test plot/print, press again to stop	
<b>COUNTER RESET</b>	Short press does nothing. Intermediate press changes to Configuration state. Long press to reset Media Count.	

#### 6.3.1 Offline State Keypad/Display Functions

As the internal logic initializes the Offline State, various functions are performed, including formation of the Self Test pattern in memory. Depending upon the previously configured pattern, this may take up to 15 seconds. During this period the display shall indicate:

**Standby-ImageBld**

During this time, all keypad keys are non-functional. When the display returns to the "Media Used" or "Media Left" indication, the Offline state shall then be in effect, as described below.

When in the Offline state, the keypad is fully functional.

- **ONLINE** key press serves as a request to go to the Online state. This is honored only if the plotter is idle, ie. Feed or Test is not currently underway.
- **PAPER FEED** key press while the plotter is idle causes media feed to begin immediately.  
If the key is released within approximately 0.5 second, then a Form Feed is triggered. The media is advanced a distance as would be done by a host triggered Form Feed (see Section 7.13 -- Form Feed Length).  
If instead, the key is held for longer than this period, continuous feed occurs as long as the key is held pressed, thus allowing the user to feed any amount.
- **SELF TEST** key press while the plotter is idle causes the previously configured self-test plot or print pattern to be output. Only a momentary key press is required to trigger the test plot. The type of test plot or print is selected through the Configuration state. Test plot or print can be ended at any time by a second momentary **TEST** key press. Some patterns inherently stop after a preset output distance. See Section 7.2 -- User Configuration State, Test Pattern Selection, for a detailed description of each pattern.
- **COUNT RESET** key has a dual function; to reset the Media Count (as may also be done in the Online state) and to enter the Configuration state.

Upon detecting a press on this key, the front panel display responds by displaying:

**Hold to ResetCnt**

for approximately 2 seconds. If the **COUNT RESET** key is released before the end of this period, then the display is restored to its former message with the Media Count unchanged. If the key is held pressed through this period, then at the end of it, the display changes to:

**Release to Cnfig**

for another period of approximately 2 seconds. If the **COUNT RESET** key is held pressed for this additional period, then one of the following appears on the display:

**MediaUsed: \_\_ ft**

**MediaLeft: \_\_ ft**

**MediaUsed: \_\_ m**

**MediaLeft: \_\_ m**

When the key is released, the actual numeric field (properly reset) is inserted in place of the "\_\_\_" field.

Instead, if the **COUNT RESET** key is released within this second period (in response to "Release to Cnfig"), then the plotter enters the Configuration state. The user will then be presented with initial display for Configuration menu selection (User or Service), and from there may proceed to observe and/or change plotter configuration. This is discussed completely in Sections 7 and 8 on the Configuration state.

### 6.3.2 Sensor faults

Sensor-fault based alarm conditions (ie. Out of Media, Printhead Lifted, Mechanical Stall) which occur while in the Online state cause immediate stoppage of any plot/print which may be underway and change to the Alarm state.

### 6.3.3 Offline State Output Speed

The effective output speed for **PAPER FEED** and **SELF TEST** functions is a product of many factors:

- The configured Test Pattern implies a specific maximum speed
- Configured Energy Level (see Section 7.1)
- Configured Chart Speed Limit (see Section 7.3). This is applicable only if the Self Test Speed Control (see Section 7.16) is configured for "**OnlineCfg**". If "**Maximum**" is selected, this limit shall not apply.
- Possible slowdown may be enforced by a sensed high temperature condition at the printhead (see Section 4.4.3)
- Constant slow speed may be forced by a DIP switch setting (S3) on the Controller Board. Normally, stations 1-5 would all be in the Off position to enable full speed operation.

## 6.4 Alarm State

### 6.4.0 General

The plotter is equipped with sensors for the detection of conditions which could cause damage to internal components. When a problem condition is detected, the current state of operation is ended and a special sensor fault handling state is entered. This is made evident by an **ALARM** indication and an accompanying message on the display to explain the problem.

**Table 7 -- Summary for Alarm State**

Indicators	Status	Notes
<b>ONLINE</b>	Off	Interface is inactive (INOP asserted)
<b>ALARM</b>	On	
<b>LOW TEMP</b>	Off/On	Both Off or one On in accordance with current printhead temperature
<b>HIGH TEMP</b>	Off/On	
<b>Display</b>	Indicates fault sensed	
<b>Keys</b>	<b>Function</b>	
<b>ONLINE</b>	No function	
<b>PAPER FEED</b>	Momentary key press triggers approx 4 inch platen advance	
<b>SELF TEST</b>	No function	
<b>COUNTER RESET</b>	No function	

### 6.4.1 Responses to common Sensor Faults

#### "Printhead Lifted"

**Printhead Lifted**

The cause of this is self explanatory; the gap interrupt sensor has detected that the printhead lift lever has been moved to a position close to unlocking the head. Its function is to insure that the printhead is not pulsed without media in contact with the thermal dot elements.

Corrective action is simply to restore the lever to its "full in" locked position. The plotter should respond by advancing media for approximately 0.3 inch (8 mm). During this period the display should report:

**Standby--Sensors**

while all sensors are tested for proper action. If no fault is then seen, the Offline state is entered. Otherwise, the plotter remains in the Alarm state and the problem is reported on the display.

## "Out of Media"

### Out of Media

A reflective optical sensor is installed in the media guide bar just under the platen roller. Its function is to insure that the bare platen does not rub against the printhead when media has been used up. If the media is consumed, or if for any other reason the web is not detected, then a fault is declared. This may result from excessive wrinkling or bulging in the web in front of the sensor, such that the reflective surface is disturbed. The sensor is designed to function with the media tight (or nearly so) against the guide bar.

Corrective action should be first to lift the printhead by pulling the locking lever out. Then reload media with attention to smooth travel over the guide bar. With the media loaded correctly, the display should then report:

### Printhead Lifted

At this point, push the locking lever back in. The plotter should respond as outlined above for "**Printhead Lifted**".

If translucent or transparent media is in use, the reflective sensor may not function correctly. If necessary, it is possible to logically mask the Media Sensor using a function described in the User Configuration Menu (see Section 7.4). It is necessary to temporarily "fool" this sensor by installing media (or simply attach white adhesive tape over the media guide bar in the vicinity of the sensor) so that the plotter can be operated in the Configuration state in order to carry this out. When operating in this mode, the Mechanism Stall sensing feature is essential for performing the required shutdown in the case of normal exhaustion of the media supply.

**Caution:** Never operate the plotter with the Media Sense control (accessible in User Configuration Menu) and Stall Sense control both Disabled.

## "Mechanism Stall"

### **Mechanism Stall**

The platen roller is equipped with a rotation sensor. Periodically, based upon a preset number of drive motor steps, this sensor is checked to make sure that rotation has occurred. This is to insure that media is travelling under the thermal dot elements, thus performing an essential heat sinking function.

Cause of this fault may be broken drive belt, loose pulley in the drive path from the motor, electrical malfunction, or mechanical seizure in the platen assembly. Another possibility is that the Media Sensor has been disabled (as discussed above), in which case, exhaustion of the media supply will result in a Mechanical Stall.

If this fault occurs, first to lift the printhead by pulling the Printhead Lift Lever out and up. The display should then report:

### **Printhead Lifted**

Look for the cause of the stall, and correct if possible. At this point, push the Printhead Lift Lever back in. The plotter should respond as outlined above for "**Printhead Lifted**".

## 6.4.2 Alarm State Media Feed

To facilitate media loading, capability is provided to trigger a momentary media feed which will assist the operator in threading media into and through the mechanism. Anytime while the Printhead Lift Lever is in the release position, a momentary press of the **PAPER FEED** key shall initiate platen roller advance for approximately 4 inches (10 cm) at a 1 inch/sec (2.5 cm/sec) rate. This is intended to give the operator opportunity for threading and guiding of media with both hands available and assisted by platen roller motion. It is possible to execute this whether or not media is in position at the media sensor, as long as the Printhead Lift Lever is in the released position.

## 6.5 Trap Report State

Self-detection of illegal logical conditions (referred to as "Traps") by internal plotter software will cause interruption of normal execution and safe shutdown of critical processes. Trap addresses are reported to the display for diagnostic purposes. Trap Report State is indicated by the Alarm indicator On, and one of the following messages at the display:

**PrTRAP \_@ \_\_\_\_\_** or **Ct TRAP @ \_\_\_\_ \_**

The display fields shown as " \_\_\_\_ " should be filled with a hexadecimal number. These refer to trap addresses on the Processor and Controller Boards, respectively. This information should be reported to Atlantek as an aid in diagnosis.

Alternatively, an erroneous condition may be reported in text on the display for situations which could result from user error or host system malfunction. The following messages may be found:

**Halt:Infce \_\_\_\_\_**

where " \_\_\_\_ " is one of:

**RLTER**  
**RFFED**  
**REOTR**  
**CLEAR**

As outlined in Section 5.2, this message indicates a trap has occurred as a result of the host system holding one of the remote command input line asserted, contrary to the handshake protocol indicated by negation of the interface **READY** output.

**Halt:IlegSnsMask**

This indicates detection of the illegal condition of having both the Media Sense function masked (as may be done according to Section 7.4) and the Stall Sense function masked (according to Section 10.1). It is recommended that the operator remove JP4 on the Controller Board, and if required, determine the Mechanism Stall fault and repair.

While in the Trap Report state, all keys are non-functional. This state persists indefinitely until the plotter is power cycled.

## 6.6 Configuration State

### 6.6.0 General

The plotter incorporates an easy to use, menu-oriented program for observing current plotter configuration, and for change of all alterable parameters where applicable. All changes, including Service Polls and Diagnostics, may be performed under front panel keypad control. Note that the execution of Configuration state functions require that an alternative interpretation for each key must be observed in place of the labelled function for that key.

**Table 8 -- Summary for Configuration State**

Indicators	Status	Notes
<b>ONLINE</b>	Off	Interface is inactive (INOP asserted)
<b>ALARM</b>	Off	
<b>LOW TEMP</b>	Off/On	Both Off or one On in accordance with current printhead temperature
<b>HIGH TEMP</b>	Off/On	
<b>Display</b>	Shows one configuration parameter and current selection if applicable	
Keys	Function	
<b>ONLINE</b>	Press to accept current selection, display next parameter in sequence	
<b>PAPER FEED</b>	Press to increment current selected option	
<b>SELF TEST</b>	Press to decrement current selected option	
<b>COUNTER RESET</b>	Press to exit Configuration state, goes to Offline state	

#### 6.6.1 Configuration State Keypad Functions

- **ONLINE** key press serves as a "Next Parameter" function, in effect accepting the previous parameter as last displayed and presenting the following parameter in sequence for observation and potential change by the operator.
- **PAPER FEED** key press normally serves to advance the parameter selection currently displayed to the next numerically higher option.
- **SELF TEST** key press normally serves to advance the parameter selection currently displayed to the next numerically lower option.

Note that both **PAPER FEED** and **SELF TEST** key presses in Configuration State wrap the selected parameter around when the choice has been advanced beyond the allowed selection range. For parameters which are numerical in nature (Plot Width and Media Reset Length, for example) an auto-scrolling feature has been implemented such that large changes in count value can be performed within a reasonable time. The user needs only to hold the key (**PAPER FEED** or **SELF TEST**) down and the count rate shall increase automatically. The user should then release the key when the target value has been approached. Individual key presses can then be used for fine tuning to the target value.

If the configuration choice for a parameter is binary (ie. only 2 options exist), then **PAPER FEED** and **SELF TEST** both serve to toggle the choice, and their actions are identical.

- **COUNT RESET** key press serves to exit the Configuration State to the Offline State, thus accepting all Configuration parameters in the state they had been previously with any applicable changes.

Instructions for accessing the Configuration State follow.

### 6.6.2 Entering Configuration State

The Configuration State can be accessed with the plotter in the Offline state, and idle (ie. not in process of performing media feed or test plot/print functions). This is outlined in detail in Section 6.3 -- Offline State, Keypad and Display Functions

### 6.6.3 Menu Selection

The overall function of Configuration state is to present the user with information pertaining to plotter configuration and, in some cases, effect changes to alterable parameters. The sum total of parameters is, for convenience sake, divided into two menu branches, User and Service. Each menu branch offers a sequence of parameters for observation and/or change. The first choice in Configuration state is to select the branch which shall be followed for the sequence of subsequent parameters.

Display Format

<b>MenuAccess: User</b>	or	<b>MenuAccess: Serv</b>
-------------------------	----	-------------------------

The user can at this point change the selected menu sequence branch (using the **PAPER FEED** or **SELF TEST** keys) which shall be displayed upon future pressing of the **ONLINE** key. Items in the Service menu sequence are for diagnostic purposes and are not intended for alteration without specific instructions from Atlantek or its authorized service representative. The Service menu is covered in detail in the Service manual. All items which the user shall normally need to view or change are accessible within the User menu sequence.

## 7. Configuration -- User Menu

### 7.0 General

The parameters listed as follows below comprise the set of alterable functions. Each parameter is accessed in sequence by successive presses of the **ONLINE** key. At any time in this sequence, pressing the **COUNT RESET** key shall exit the plotter from Configuration and restore the Offline State. The **PAPER FEED** and **SELF TEST** key functions change slightly between parameters but generally these serve to increment/decrement the selection currently displayed for each parameter.

### 7.1 Energy Level Selection

Display format:

<b>Energy Level:</b> _
------------------------

Choices available:

- 1 \*
- 2
- 3
- 4

\* denotes selection invoked by configuration flush

In order to accommodate a wide array of thermal imaging media types, the plotter supports user configuration of the thermal printing energy level. Generally, the higher the energy level, the darker the image; and because of the internal controls of the plotter, the slower the maximum chart output rate. This speed restriction is imposed in order to limit overall printhead dissipation to safe levels. Recommended energy level setting depends mostly upon the currently installed thermal media, although personal preferences and output speed requirements are also factors in this decision. The selected energy level shall be effective in all printing conditions; including Online host-driven plotting and printing, and Offline Paper Feed and Self-Test print/plot patterns. Energy level recommendations and the resultant speed limits are summarized by the following table:

**Table 9 -- Energy Level Characteristics**

Energy Level	Maximum Speed (inch/sec),(mm/sec)	Application
1	5.00, 127	Lightweight, Non-topcoated papers
2	3.83, 97	Heavier, Non-topcoated papers Light, Topcoated papers
3	2.66, 68	Heavy topcoated papers Opaque Synthetic and High Speed Films
4	2.08, 53	Most Film media

## 7.2 Test Pattern Selection

Display format:

<b>TstPat:</b> _____
----------------------

Choices available:

**ZigZag** \*  
**Grid**  
**Lines**  
**CharSet**  
**NaroBand**  
**Waveform**

\* denotes selection invoked by configuration flush

The user may select the test pattern which is to be output upon actuation of the **SELF TEST** key in the Offline state. A momentary press of this key starts the plot. A second momentary press of the key also stops the plot. Some patterns will also terminate after a certain length of output. Available pattern are:

- **ZigZag** pattern consists of a filled pattern which presents a variable dot load on the printhead in order to perform a worst case imaging density test. Once started, this pattern runs until stopped by the keypad.
- **Grid** pattern plots a 11 inch wide by 25 inch high rectangular grid. This pattern is useful for checking chart calibration accuracy. The pattern runs by itself just over 25 inches (63.5 cm) but it may be terminated early by the keypad.
- **Lines** pattern plots 1 of every 8 dots across the entire active span (2336 dots, or 11.68 inch; 297 mm, approx.) of the printhead, according to the current dither state and centering position configuration. The pattern is repeated vertically for approximately 0.15 inch (4 mm), then shifted 1 dot. The sequence is repeated indefinitely, thus testing every dot in the active span of the head. Non-printing dots are obvious because of a resultant interruption of the pattern. It is normal to see minuscule skips and dropouts in these lines, because of the fineness of the dots and graininess in the media. This can be mitigated by operating at the highest Energy Level setting. Once started, this pattern runs until stopped by the keypad.
- **CharSet** pattern prints the entire internal character font, 196 characters across. The pattern runs by itself for 96 character lines but it may be terminated early by the keypad.
- **NaroBand** pattern plots a cycling band of squares, each with its own internal pattern of on/off dots, in both horizontal and vertical axes. This pattern is used by Atlantek Inc. for testing purposes. It may be useful for the user in evaluating the performance of media at different Energy Levels. Once started, this pattern runs until stopped by the keypad. If this pattern is selected through the Configuration process, the following menu parameter is "**PatnLocn**". This permits the user to set the location of the NaroBand pattern from extreme right (0) to left (256). The number displayed is in units of 8 printhead dots (0.040 inch; 1 mm approx.) and describes the distance from the right-hand edge of the active plot zone to the right-hand edge of the NaroBand pattern.
- **Waveform** pattern plots a sequence of horizontal waveforms with shade filled peaks. This pattern runs for approximately 32 inches (81 cm), then stops by itself, but it may be terminated early by the keypad.

### 7.3 Chart Speed Limiting

Display format:

**SpdLmt: \_\_\_ in/s**

**SpdLmt: \_\_\_ mm/s**

Choices available:

"in/s" display mode

"mm/s" display mode

<b>0.12</b>	<b>3</b>
<b>0.31</b>	<b>8</b>
<b>0.51</b>	<b>13</b>
<b>0.70</b>	<b>18</b>
<b>0.90</b>	<b>23</b>
<b>1.10</b>	<b>28</b>
<b>1.30</b>	<b>33</b>
<b>1.49</b>	<b>38</b>
<b>1.68</b>	<b>43</b>
<b>1.88</b>	<b>48</b>
<b>2.08</b>	<b>53</b>
<b>2.27</b>	<b>58</b>
<b>2.47</b>	<b>63</b>
<b>2.66</b>	<b>68</b>
<b>2.85</b>	<b>72</b>
<b>3.05</b>	<b>77</b>
<b>3.25</b>	<b>83</b>
<b>3.45</b>	<b>88</b>
<b>3.63</b>	<b>92</b>
<b>3.83</b>	<b>97</b>
<b>4.03</b>	<b>102</b>
<b>4.22</b>	<b>107</b>
<b>4.43</b>	<b>113</b>
<b>4.63</b>	<b>118</b>
<b>4.81</b>	<b>122</b>
<b>5.00 *</b>	<b>127 *</b>

\* denotes selection invoked by configuration flush

**Note:** Energy Levels 2,3 and 4 shall limit the selection range of the Chart Speed Limit to those values which are within the limit indicated in Table 9.

The user has the ability to place a maximum limit upon chart output rate through the use of a User Menu configuration parameter. The plotter is capable of adapting to variable data rates from the host system without loss of data or the introduction of gaps in the plotted output. However, when large speed fluctuations result from discontinuous host data flow, some density variations may be noticed. For the most demanding applications, the user may choose to limit the maximum chart output rate in order to eliminate these variations. The speed limit imposed by this configuration is effective in all Online print/plot output, excluding blank media feed. Offline state Paper Feed and Self Test may also be limited by this parameter depending upon the state of another control (see Section 7.16).

## 7.4 Media Sensor Enable/Disable

Display format:

**MediaSens:** \_\_\_\_\_

Choices available:     **Enable** \*  
                              **Disable**

\* denotes selection invoked by configuration flush

The plotter incorporates a reflective optical sensor in the media guide extrusion, facing the forward just below the platen roller. The purpose of this is to halt printing should the media be used up. This function is entirely adequate when media or other opaque media is installed. Problems may be experienced, however, when installing transparent or translucent films. In this case, the user may notice an "**Out of Media**" Alarm condition even though the film is truly installed in the proper position. Therefore, a Configuration parameter is implemented which permits the user to disable the Media Sensor should this become necessary. If the Media Sensor is disabled, the Rotation Sense function is the only means to halt printing when media is used up. Simultaneous masking of both Media Sensor and the Rotation Sensor (Sections 8.3 and 10.1) is hazardous to the plotter and shall result in a Trap Alarm (see Section 6.5).

**Note:** A change to this parameter does not become effective until the Configuration State is exited to the Offline State. At this point any previous change in this parameter will then be effective.

## 7.5 Plot Width

Display format:

**Plot Width:** \_\_\_\_\_

Choices available:

**16**  
to  
**292** \*  
to  
**1020**  
in steps of **4**

\* denotes selection invoked by configuration flush

The plotter can be reconfigured to alternative virtual plot widths in order to emulate other plotters. This is especially important if it is desired to use automatic byte-count based line framing. The number displayed represents the width in user bytes (ie. 8 user plot bits). Therefore, for a configured Plot Width of "N"; the physical width is  $N * 0.040$  inch (1 mm, approx.) for 200 dot/inch resolution. For plot width settings less than the maximum plot field width (292), the default location of the data on the chart is aligned at the right-hand edge as it would have been for full width plotting, and extra space resides at the left-hand side. Plot width settings can be greater than the maximum plot field width, in which case the data sent first for each line fills the field normally up its maximum extent, and the data sent after that for each line is discarded. The setting of Plot Width is effective only for host supplied data and does not affect any test patterns.

## 7.6 Plot Location

Display format:

**Plot Locn:** \_\_\_\_\_

Choices available:

**0** \*  
to maximum (see below)  
in steps of **2**

\* denotes selection invoked by configuration flush

Configuration of Plot Location allows the user to relocate plot fields of less than full width. The number displayed represents the leftward indent distance in user bytes (ie. 8 user pixel bits). The maximum this may be configured to is the difference between the full width in user bytes (292) and the configured Plot Width. The setting of Plot Location is effective only for host supplied data and does not affect any test patterns.

## 7.7 Print Width

Display format:

<b>Prnt Width:</b> _____
--------------------------

Choices available:

**8**  
to  
**196** \*  
to  
**1020**  
in steps of **1**

\* denotes selection invoked by configuration flush

The plotter can be reconfigured to alternative virtual print widths in order to emulate other plotters. This is especially important if it is desired to use automatic byte-count based line framing. The number displayed represents the width in user bytes (same as number of characters) per print line. Therefore, for a configured Print Width of "N"; the physical width is  $N * 0.080$  inch (16 dots \*  $1/200$  inch = 0.080 inch = 2.0 mm per character cell). For print width settings less than the maximum print field width (196), the default location of the data on the chart is aligned at the right-hand edge as it would have been for full width printing, and extra space resides at the left-hand side. Print width settings can be greater than the maximum print field width, in which case the data sent first for each line fills the field normally up its maximum extent, and the data sent after that for each line is discarded. The setting of Print Width is effective only for host supplied data and does not affect any test patterns.

## 7.8 Print Location

Display format:

<b>Prnt Locn:</b> _____
-------------------------

Choices available:

**0** \*  
to  
maximum (see below)  
in steps of **1**

\* denotes selection invoked by configuration flush

Configuration of Print Location allows the user to relocate print fields of less than full width. The number displayed represents the leftward indent distance in character cell widths (ie.  $16 * 1/200$  inch = 0.080 inch = 2.0 mm). The maximum this may be configured to is the difference between the full width in user bytes (196) and the configured Print Width. The setting of Print Location is effective only for host supplied data and does not affect any test patterns.

## 7.9 Dither Control

Display format:

<b>Dither:</b> _____
----------------------

Choices available:      **Enabled \***  
                                 **CenterPos**

\* denotes selection invoked by configuration flush

Dither is offered in the plotter as a means of walking the print/plot image by small amounts within a larger field so that dots, which are frequently energized due to a border, grid, or other unchanging plot feature, are not plotted when the image is moved. Dither shift is actuated by either of 2 events:

- A normal plotter power-up initialization.
- A keypad-actuated Online to Offline state change.

The dither shift sequence encompasses 5 possible image positions, each 8 printhead dots (0.040 inch; 1.0 mm, approx) apart. The effective image span shall walk between these positions if dither configuration is **Enabled**. The user can mask this process and so fix the image position by selecting **CenterPos**. Dither is applied in the same way to all host supplied print/plot data, as well as to internally generated test pattern data.

## 7.10 Media Counter Mode

Display format:

<b>MediaDsply" _____"</b>
---------------------------

Choices available:      **Used \***  
                                 **Left**

\* denotes selection invoked by configuration flush

The user has the option to view the media length count at the front panel display in either of two modes. In the "Media Used" mode, the Count Reset function resets the media length count to 0 and the value counts up from there. This is most useful when the media roll length is not known or changes frequently. In the "Media Left" mode, the Count Reset function resets the media length count to a given number (presumably the roll length in feet) and the value counts down from there. The reset value is also configurable (see Media Length configuration) so that if the roll length is known, it can be stored internally.

## 7.11 Display Units Mode

Display format:

<b>DisplyUnit:</b> _____
--------------------------

Choices available:

**ft,in \***  
**m, mm**

\* denotes selection invoked by configuration flush

Those displayed quantities involving distance or speed can be configured for display in either of the following ways:

- feet, inches, or inches per second
- meters, millimeters, or millimeters per second

This control is provided for convenience of the user and does not effect plotter function other than the display text. Plotter dot resolution and chart advance is designed according to inch-based standards (ie. 200 dots/inch, not 8 dots/mm). Therefore the "ft,in" displayed quantities are generally more accurate than the nearest equivalent "m, mm" quantities.

## 7.12 Media Reset Length

Display format:

<b>MediaLen:</b> _____ <b>ft</b>	<b>MediaLen:</b> _____ <b>m</b>
----------------------------------	---------------------------------

Choices available:

"ft" display mode

"m" display mode

	<b>0</b>	<b>0</b>
	to	to
	<b>200 *</b>	<b>60 *</b>
	to	to
	<b>1000</b>	<b>300</b>
in steps of	in steps of	
	<b>1</b>	<b>1</b>

\* denotes selection invoked by configuration flush

This parameter allows the user the ability to accurately display "Media Left" as long as the roll length at the start is known.

### 7.13 Form Feed Length

Display format:

<b>FF Len: ____ in</b>	<b>FF Len: ____ mm</b>
------------------------	------------------------

Choices available:

"in" display mode

"mm" display mode

**0.5**

to

**2.5 \***

to

**12.5**

**13**

to

**64 \***

to

**318**

\* denotes selection invoked by configuration flush

Form feed advance distance can be configured using this parameter. Form feed is actuated through the host interface either through asserting the RFFED (Remote Form Feed) signal (in either Plot or Print modes) or by sending the FF character (0A<sub>hex</sub>) in the Print mode. Form feed may also be actuated by a quick (less than approximately 1 second) press of the **FEED** key while in the Offline state.

### 7.14 End-of-Transmission Feed Length

Display format:

<b>EOT Len: ____ in</b>	<b>EOT Len: ____ mm</b>
-------------------------	-------------------------

Choices available:

"in" display mode

"mm" display mode

**0.5**

to

**8.0 \***

to

**12.5**

**13**

to

**203 \***

to

**318**

\* denotes selection invoked by configuration flush

End-of-Transmission advance distance can be configured using this parameter. End-of-Transmission feed is actuated through the host interface either through asserting the REOTR (Remote End-of-Transmission) signal (in either Plot or Print modes) or by sending the EOT character (04<sub>hex</sub>) in the Print mode.

## 7.15 Default Power-Up State Control

Display format:

<b>DefPwrUp:</b> _____
------------------------

Choices available:      **Online \***  
                                 **Offline**

\* denotes selection invoked by configuration flush

This selection allows the user to control the state into which the plotter shall normally proceed following Initialization. As described in Section 6.1 -- Initialization, the plotter can be configured to proceed into either Online or Offline State, in accordance with the selection invoked by this menu item.

If the **ONLINE** key is pressed and held upon power-up, then the state contrary to that selected at this menu shall be entered.

## 7.16 Self-Test Output Speed Control

Display format:

<b>TstSpd:</b> _____
----------------------

Choices available:      **OnlineCfg \***  
                                 **Maximum**

\* denotes selection invoked by configuration flush

This selection allows the user a means to control the output speed for generation of Self Test plots in the Offline state. For the default configuration, "**OnlineCfg**", the same speed limit applicable for Online print/plot as configured in Section 7.3 -- Chart Speed Limiting, is also applied for Offline self-test plots. If this control is changed to "**Maximum**", then self-test plots shall be output unlimited by the Speed Limit control. Self-test output speed shall still be limited by the configured Energy Level, and an inherent pattern-specific speed limit.

This control is intended for the user who may elect a slow Online plot speed, yet finds it convenient to perform Offline state Paper Feed and Self Test at a faster speed. Otherwise it is recommended to keep this control in the "**OnlineCfg**" state.

## 8. Configuration -- Service Menu

### 8.0 General

The parameters listed below are of interest to those who may be called upon to analyze plotter internal functions as would be required for servicing. For the most part, parameters displayed in the Service Menu are unalterable and should be considered as status reports and not, as the nomenclature might imply, "Configuration" as such. Each parameter is accessed in sequence by successive presses of the **ONLINE** key. At any time in this sequence, pressing the **COUNT RESET** key shall exit the plotter from Configuration and restore the Offline State. As in the User Configuration Menu, the **PAPER FEED** and **SELF TEST** keys serve, in the case of those parameters which are alterable, to increment or decrement, respectively, the parameter on display.

### 8.1 Printhead Temperature Report

Display format:

<b>PrthdTemp XX.X°C</b>
-------------------------

This reports allow field service personnel to poll thermal printhead temperature, as determined from the average of the readings from the internal printhead thermistors. The result provides useful information as to the wellness of thermal management components and software.

## 8.2 Software Status Report

Display formats:

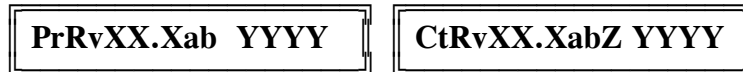

These reports allow field service personnel to poll the plotter for the ROM Software Revision Level and ROM Checksum (displayed as 4 hexadecimal digits) of each of the two major boards in the plotter.

- The header "**PrRv**" indicates the following information pertains to the Processor Board.
- The header "**CtRv**" indicates the following information pertains to the Controller Board.

The information fields are described as follows:

- XX.X** is the board Software Revision level. This is displayed as an upper-case letter, numeral, decimal point and numeral. For example: "**A2.5**"
- a** is the plotter model-specific version identifier. This is displayed as a lower-case letter, and should agree between Processor/Controller.
- b** is an additional version identifier specific to each plotter model. This is displayed as a blank or a numeral.
- YYYY** is a hexadecimal checksum value specific to the ROM-based code in each board, useful for internal factory tracking.
- Z** is a board Hardware Revision identifier. This is displayed as an upper-case letter. In other Atlantek plotters this distinction is important but it has no significance in the Model 1200R.

Internal logic performs cross-checking of the software revision and version of both boards to determine compatibility of board software. Failure to meet internal criteria for Processor/Controller version and revision level shall result in a "**Firmware Mismatch**" internal error being flagged at power-up (see Table 13).

### 8.3 Rotation Sense Mask Report

Display format:

**RotnSens:** \_\_\_\_\_

Possible responses:

**Enable**  
**Disable**

The plotter incorporates a gap-interrupt optical sensor to provide feedback to the control electronics that the platen roller is responding to expected stepper motor drive. The purpose of this is to halt printing should the drive system fail, thus protecting the printhead from overheating due to the lack of media motion. For troubleshooting purposes, this function may be bypassed by applying a shunt to jumper plug JP4 on the Controller Board (see Section 10.1). In this case, the plotter internal logic shall continue to operate even though no motion is detected at the platen. This menu poll allows the operator to determine whether the masking jumper has been applied without opening the cover.

Simultaneous masking of both Media Sensor (Section 7.4) and the Rotation Sensor is a condition deemed hazardous to plotter reliability and shall result in a trap condition alarm (see Section 6.5).

### 8.4 Printhead Serial Number

Display format:

**PhSN:** \_ \_\_\_\_\_

For factory tracking purposes, a printhead serial code identifier has been assigned. The actual printhead serial number shall be displayed at this menu item, and is stored in the NVRAM device on the Processor Board.

### 8.5 Printhead Segment Resistance Entry

Display format:

**Prthd Res:** \_\_\_\_\_

Provision is made for entry of the average dot resistance of the printhead as labelled by the manufacturer. This value shall be used internally to derive the recommended print voltage setpoint display (see Section 8.6).

## 8.6 Print Voltage Setpoint Reference

Display format:

Set Vp to \_\_\_\_ V

This item is offered as an aid to service personnel. The value displayed is derived from the preset Printhead Segment Resistance value as outlined in Section 8.5. This used to perform a lookup functionally identical to Table 11 for display of the recommended print voltage setpoint.

**Caution:** This display feature offers a voltage setpoint reference only. It does not indicate actual power supply output voltage.

## 8.7 Odometer Count Reports

Display format:

LnCnt X.XXXXXeYY

DCt1 X.XXXXXeYY

DCt2 X.XXXXXeYY

DCt3 X.XXXXXeYY

DCt4 X.XXXXXeYY

Internal plotter electronics maintains cumulative totals of media advance distance and the number of printhead dots actuated for the purpose of compiling life statistics. These counts may be polled in the Service menu.

- The header "**LnCnt**" indicates the cumulative media advance length over the life of the unit from date of shipment.
- The headers "**DCt1**", "**DCt2**", "**DCt3**", and "**DCt4**" indicate the cumulative number of printhead dot actuations for each of the three Energy Levels; 1, 2, 3, and 4 respectively, from date of shipment.

## 8.8 Internal Diagnostics

Display formats:

<b>RAM Test</b>	<b>TotlizerTest</b>	<b>ShftOutTest</b>
-----------------	---------------------	--------------------

A set of internal diagnostics has been included for the purpose of conducting confidence tests on the Processor Board. These, together with the Power Up Confidence Tests which are automatically executed with every start up, comprise an extensive set of tests which can with good confidence, determine overall wellness of the Processor Board.

Each of these tests may be invoked by momentarily pressing either the **PAPER FEED** or **SELF TEST** keys. As the test executes, a numeric field shall appear in the right-hand side of the display, counting at approximately 1 count per second. When the test is completed, a "Pass" or "Fail" response shall appear in this location.

**Note:** The "ShftOutTest" diagnostic, which conducts a data fidelity check on the outgoing printhead dot data (being sent to the Controller Board), is only accessible with an i.c. (4K x 9 Fifo), installed in a socketed location in the Processor Board.

PC Brd Artwork Rev	Device Number	Location
600502, Rev 0	IDT7204-50P	U53
600502, Rev B	IDT7204-50TP	U48

After running any of these diagnostics, false data may appear upon subsequent print/plot. If this is not desired, power cycle the plotter after performing a diagnostic test.

## 8.9 Power-Up Self-Test Error Code

Display formats:

<b>PostErrCode</b> ____
-------------------------

As discussed in Section 6.1.2, internal tests are conducted upon power-up initialization to assess wellness of the system electronics (a process commonly called "*POST*" for "*Power-On Self-Test*"). The result of these tests is coded as specific bits in a 4 hexadecimal digit number, and stored. The stored result may be polled using this item in the Service Configuration Menu. An all zero result indicates that no errors were detected upon POST (displayed as "**Error Code: Pass**" in the Initialization sequence). Any errors detected are indicated by a non-zero code both in the Initialization sequence and in the underlined field as shown above. The significance of specific bits for error code display is outlined in Section 10.7.3.

## 9. Media

Atlantek stocks a variety of media types for different requirements. The following table summarizes these types.

**Table 10 - Thermal Media Reference**

Media Type	Recommended Energy Level See Section 7.1	Atlantek Part No. See Note below	Description
Draft	1	747030-X	Facsimile Grade Paper Non-topcoated
Report	1 or 2	747037-X	Heavier Grade Paper Non-topcoated
Premium	2 or 3	747038-X	Heavier Grade Paper Topcoated
Translucent	3 or 4	747044-X	Synthetic plastic media with a vellum-like appearance
Film	4	747051-X	Synthetic clear media

Note: The -X suffix denotes roll length  
 -2 for 200 feet (61 m)  
 -5 for 500 feet (152 m)

- **Draft** grade media is a general purpose, light-weight media for use in high speed, continuous plotting applications and for high volume check plotting in CAD and scanned document retrieval. Draft grade paper produces a high contrast black image on a smooth, bright, white background which may be marked with black or colored pencil.
- **Report** grade media is the ideal paper for applications where plots are retained and more heavily handled. Report grade paper utilizes a thicker base stock, approximately 20% heavier weight than Draft grade, that is less susceptible to wrinkling and folding. Report grade paper may be also be marked with a pencil.
- **Premium** grade media, the best paper-based material, will produce exceptionally bright, crisp, high contrast images on easy-to-handle, heavy-weight stock. In addition, Premium grade is fabricated with a protective top-coating which makes the plot impervious to scratching and staining. The top-coat reduces the sensitivity somewhat, thus requiring plotter operation at a higher Energy Level.
- **Translucent** synthetic media is a plastic-based, medium weight material that produces superior plot quality at reasonable plotting speeds. Like Premium grade paper, Translucent media will not scratch or finger mark and will conduct light, making this ideal for plot data comparisons on a light table, and for making diazo copies.
- **Film** synthetic media, is similar to Translucent except for being optically clear. It has superior handling and marking qualities and is ideal for making diazo copies. Film media requires operation at the highest Energy Level to attain good blush characteristics.

## 10. Service

### 10.1 Major Functional Components

1. **Thermal Printhead:** This is the major component of the plotter. Its function is to generate localized heat patterns along a continuous linear array of dots such that the desired image is formed on the media. The image is formed one horizontal scan line at a time. The printhead receives logic signals from the Controller Board and print power from the Power Distribution Board.

Background heaters are attached to the printhead for the purpose of maintaining a temperature elevated from normal room ambient. These are mounted to a plate which is hidden from view by the large extruded carrier bar on top on the printhead.

2. **Mechanism:** This provides the necessary critical alignment between the Printhead dot line and the Platen roller, such that best image quality results. In addition, the mechanism provides support for the media supply roll, and a means for the user to thread media.
3. **Processor PC Board:** This pc board provides the electronic logic for interfacing with the host system, front panel display, indicators and pushbutton keys. The Processor Board constructs Printhead-compatible dot data from the host-entered data and maintains a non-volatile count of the media used. This board is the larger of the two major pc boards visible at the right-hand side of the plotter if viewed from the front with the cover removed.
4. **Controller PC Board:** This pc board provides the electronic logic for driving the Printhead and Stepper Motor, in adaptation to Printhead substrate temperature, host data loading rate, and sensor status. The Controller asserts control over the Power Distribution Board for regulating the Printhead background Heaters. This board is the nearer of the two major pc boards visible at the left-hand side of the plotter if viewed from the rear with the panel removed.
5. **Power Distribution PC Board:** This pc board provides a low-impedance coupling path between the Print Power Supply and the Printhead. Control relays are incorporated here for the purpose of switching the background heaters on the Printhead, and to enhance correct power up/down sequencing to safeguard the Printhead. This board is located just behind the Printhead, just above the media roll compartment, and is recognizable as having large electrolytic capacitors mounted on it.
6. **Display PC Board:** This pc board supports the front panel indicator lamps, liquid crystal display, and pushbutton keys for operator interaction. It is mounted to the inside surface of the plotter case.
7. **Print Power Supply:** This provides approximately 24 V dc for driving the Printhead, media-drive Motor and background Heaters. The output voltage is adjustable and must be set according to the tagged Printhead resistance value. This power supply is located along the upper left-hand side of the plotter as viewed from the front with the cover removed. It is recognizable as the larger of the two power supplies.
8. **Logic/Motor Power Supply:** This provides 5 V dc for driving all internal logic. This power supply is located directly in back of the thermal printhead. It is recognizable as the smaller of the two power supplies.

9. **Stepper Motor:** This provides the mechanical drive for the Platen roller, as coupled through two cog belts. It is located at the extreme left hand side of the mechanism. The Stepper Motor is electrically driven by the Controller Board.
10. **Sensors:** Optical sensors as outlined below serve to protect internal components against stress operating conditions. All of these sensors are managed by the Controller Board.
  - A. **Printhead Lift Sensor:** This is a gap-interrupt type sensor, located at the right-hand end of the lift mechanism shaft. This insures that the printhead is engaged in the print position for printing to take place.
  - B. **Media Out Sensor:** This is a reflective type sensor which is mounted behind the media guide chute, at the location of the hole visible from the front of the mechanism. It is intended to halt print/plot in the event that media is consumed.

**Note:** It is possible to functionally bypass this sensor for troubleshooting purposes by selecting the Disabled mode of the Media Sensor control available in the User Configuration Menu (see Section 7.4).

- C. **Rotation Sensor:** This is a gap-interrupt type sensor optical sensor located at the left-hand end of the Platen roller shaft, so as to work with the sprocket attached to it. The sensor is intended to detect stoppage in platen rotation and to disable normal operation in the event of a belt breakage, mechanical jam, or motor drive failure.

**Note:** If, for troubleshooting purposes, it is desired to functionally bypass Rotation Sensing, this can be done by applying a shunt connection to jumper JP4 on the Controller Board. Such action can be useful if frequent Mechanical Stall alarms are occurring and it is desired to determine if this is due to a faulty sensor or sensor interconnect. **This may be employed for troubleshooting purposes only, and should not be left in place for normal plotter function.** Simultaneous masking of both Media Sensor (Section 7.4) and the Rotation Sensor is a condition deemed hazardous to plotter reliability and shall result in a Trap condition Alarm (see Section 6.5).

## 10.2 Removal / Replacement Instructions

These instructions provide information for removal/replacement of components, especially those whose removal may not be obvious to the service person. Generally, installation can proceed in the reverse order of removal.

### 1. Front/Top Cover:

Cover is fastened to main chassis by qty. 5 screws accessible at top of cover. With these removed, cover can be pivoted out at the top slightly. Cover can then be slid upwards to disengage the locating slots at the extreme bottom from shoulder bolts in the side panels.

Front Control Panel/Display assembly will remain attached to the cover. Be careful not to stress the display cable when removing the cover. The cable is long enough to permit operation with the cover removed.

### 2. Side Panels:

It is generally not necessary to remove these panels completely. If required to remove either panel, first remove the door hinge blocks fastened from underneath the chassis. Also remove 5 screws from the rear of the chassis, and the single screw at the bottom inside front of the panel which is now accessible with the door hinge removed.

Sometimes it is necessary to move the left-hand side panel for belt adjustment or motor or platen replacement. This may be done without total removal of the Panel and Door. Position the plotter with the left-hand edge overhanging a table. Then remove rear screws as discussed above. Panel may now be pivoted top rearward around the front bottom corner to expose the mechanism side.

### 3. Printhead:

This is discussed in a special section. Refer to Section 10.5 -- Printhead Replacement and Alignment.

### 4. Processor and Controller Boards:

Remove Cover. Both boards are mounted in slide rails in top right-hand corner. Disconnect cables, remove top clamp and slide boards out top.

### 5. Power Supplies:

Remove Cover. The Print/Motor power supply is located at the extreme left side near the top. The Logic power supply is directly behind the printhead, and to the left of center. Remove either supply with its mounting bracket using the fasteners accessible from the rear of the chassis.

### 6. Display Board:

Remove Cover as described. Display Board will remain attached to Cover and can be easily removed from there.

When reattaching the display to the Cover, fasten the middle 2 screws partially at first and attain preliminary button alignment with the button access holes. Ensure that all buttons work freely, then tighten all screws fully.

### 7. Platen Roller:

Remove Cover as described. Detach and pivot Left Side Panel out of the way as described. Remove Rotation Sensor mounting bracket from Mechanism main casting and allow it to hang free of sprocket. Loosen drive belts and remove front belt from Platen Roller pulley. Remove main bearing caps. Platen roller may now be swung out from mechanism at right-hand end while pivoting at left-hand end.

When reassembling platen roller into plotter, take care to position platen rotation sense sprocket in proper position within gap-interrupt sensor housing. Make notice of the roller bearing assemblies at each end of the platen shaft, and the washers just outside them. Platen roller location and free play are set by the positions in which the roller bearing outer races are clamped into the bearing caps on the mechanism. The washers just outside the bearings serve as stops for limiting platen end play. Platen axial free play should be set to 0.030 to 0.050 inch (0.8 to 1.3 mm), with the rotation sensor sprocket centered in the sensor housing slot. It is normal for the platen to "walk" axially one way upon rotation. Platen axial position should be constrained so that the sprocket cannot come into contact with the sensor housing at either extent of the allowed movement range.

Bearing cap torque is also important. Tighten the two screws at each bearing in a balanced manner. We recommend 12 to 15 inch-oz (0.8 to 1.1 kg-cm) of torque at each screw, but in no case should these screws be tightened to the point that binding in the bearings becomes noticeable.

## 8. Belts:

Remove Cover as described. The rear belt must be loosened first in order to loosen or remove the front belt.

***To remove/loosen Rear Belt:*** Loosen Stepper Motor slide-mount lockscrews from inside mechanism. Loosen jacking setscrew from underside of left-hand mechanism casting which holds motor mount up. Motor will now drop and belt can be removed.

***To remove/loosen Front Belt:*** Loosen locking setscrew from underside of left-hand mechanism casting which secured eccentric jackshaft assembly. Eccentric can now be rotated (forward edge up) to loosen front belt.

***To tighten Front Belt:*** Locate the drilled hole in the eccentric assembly and position it so the hole is on top. Use an allen wrench inserted into the hole rotate it (forward edge down) in the bore of the casting until the Front Belt is sufficiently taut, then lock in place with the setscrew from the underside of the casting. By hand rotate the platen backwards and observe belt tracking. It may be desirable to axially shift the position of the eccentric assembly in the casting to get optimum tracking.

***To tighten Rear Belt:*** Start with lockscrews lightly fastened to hold motor bracket close to casting but not locked into position. Use jacking setscrew to push motor mount into position with Rear Belt properly tensioned. Then lock motor mount in place. By hand rotate the platen backwards and observe belt tracking. It may be desirable to move the motor pulley on the shaft to get optimum tracking.

## 9. Stepper Motor:

Follow procedure for loosening Rear Belt. It is not necessary to change Front Belt. With Rear Belt slack and lockscrews removed, motor mount bracket can be removed completely with Stepper Motor attached.

#### **10. Inner Guard Plate and Power Distribution Board:**

The Power Distribution Board is attached to the Inside Guard Plate, which is the sheet metal piece just above the paper compartment.

*To remove:* Remove Cover. Loosen screws at front of Guard Plate which pinch plate in groove on back surface of Media Guide Chute. Let back of Guard Plate fall out so that front of Guard Plate can be removed from groove. Disconnect all cables to Power Distribution Board, and extract from plotter. The Power Distribution Board can now be easily removed from Guard Plate.

*To install:* Reverse procedure. Reconnect all cables with Plate/Board assembly close to working position. Make sure to engage front edge of Plate in groove before attaching screws at rear.

### 10.3 Service Mode Self-Test Patterns

An additional set of self-test patterns is accessible for the purpose of conducting service and quality-control checks. These patterns are not available in the selection sequence of Self Test Patterns, outlined in Section 7.2, as the plotter is normally shipped. Access to these extra patterns is controlled by the Processor Board DIP Switch, Station 6:

- Switch Off prevents access to service mode patterns.
- Switch On allows access to service mode patterns.

With this switch On, the extra patterns are included in the selection sequence offered in the menu. Generation of these patterns is possible only in the Offline State, as is the case for all Self Test patterns.

The available service mode patterns are as follows, as indicated by the names used in the selection menu:

- **HalfTone** pattern is a fine-dot checkerboard which produces a nearly black image for the full plot width of the printhead. Once triggered, this pattern shall output until stopped by another press of the **SELF TEST** key. This pattern is recommended for performing printhead alignment.
- **Diagonal** pattern consists of a short band of thick and thin 45° diagonal lines. A momentary press of the **SELF TEST** key triggers output of approximately 0.32 inch (8.1 mm). The function of this pattern is to evaluate performance as to the accuracy of plotting in the media advance axis under conditions of discontinuous advance. The evaluation is performed by examining the horizontal junction line between two successive actuations of this pattern.
- **Horiz Ln** pattern consists of horizontal lines 11 inches (28 cm, approx) long, repeated at a spacing of 0.20 inch (0.51 mm). Once triggered, this pattern shall output until stopped by another press of the **SELF TEST** key.

**Important:** After completing service functions, always return Processor Board DIP Switch Station 6 to the Off position.

### 10.4 Power Supply Adjustment / Configuration

There are two power supplies in the plotter, as discussed in Section 10.1, the Print/Motor Power Supply (24 V) and Logic Power Supply (5V).

**Warning:** There are components on the power supplies with exposed hazardous voltages. Use extreme caution when working on these supplies.

**1. Print/Motor Power Supply** (the different power supplies in use may be distinguished by the shape of the main mounting frame.

- **Open Frame Supply, "L"-shaped (Deltron™):** This power supply is composed of an "L"-shaped frame fixed to a major pc board and a prominent sub-assembly containing two power transistors.

*Input Voltage Configuration:* Strapping is performed by mating a set of labelled jumper plugs made from large Amp™ "MTA" connectors with a set of orange, purple, and brown wires applied. The 230 V ac selection jumper is the one with the 2 middle contacts (of 4 total) wired together.

*Adjustment:* The output adjustment potentiometer for this supply is located near the power output terminals, and is accessible with a screwdriver from the below the supply upwards toward its front corner, or alternatively, from above into the back side of the potentiometer. Turn counterclockwise to increase voltage, clockwise to decrease.

- **Open Frame Supply, "U"-shaped (Power Systems™):** This power supply is composed of an "U"-shaped frame which contains a single pc board.

*Input Voltage Configuration:* Strapping is performed by a single wire jumper with connector which connects to the left-hand side of the power supply board, near the input terminals. The connection should be made for 115 V ac operation, broken for 230V ac.

*Adjustment:* The output voltage adjustment potentiometer (labelled "OUTPUT ADJUST") for this supply is located near the power output terminals, and is accessible with a screwdriver from inside the internal cavity. Do not attempt to alter the sealed "CURRENT LIMIT" potentiometer.

The output voltage should be set according to the tagged value provided on the thermal printhead. If that is not provided, use the Print Voltage Setpoint lookup menu (see Section 8.6 and Table 11) to determine this value. The lookup may be performed manually or the setpoint value may be read off the plotter display.

**2. Logic Power Supply** -- only one model of power supply is currently in use in this application, an open-frame model by Cosel™.

*Input Voltage Configuration:* Strapping is not necessary as this supply is capable of handling a wide input voltage range encompassing all plotter operating conditions.

*Adjustment:* The 5 V dc output is adjustable on this supply. The voltage adjustment potentiometer is located in front, right-hand corner of power supply board. It is accessible from the right-hand side, clockwise to increase voltage, counterclockwise to decrease.

**Table 11 - Print Voltage Lookup Reference**

Average Resistance ( $\Omega$ )		Print Voltage (V)
min	max	
1071.0	1081.0	22.8
1081.5	1090.5	22.9
1091.0	1100.5	23.0
1101.0	1110.0	23.1
1110.5	1120.0	23.2
1120.5	1130.0	23.3
1130.5	1140.0	23.4
1140.5	1150.0	23.5
1150.5	1160.0	23.6
1160.5	1170.0	23.7
1170.5	1180.0	23.8
1180.5	1190.0	23.9
1190.5	1200.5	24.0
1201.0	1210.5	24.1
1211.0	1221.0	24.2
1221.5	1231.0	24.3
1231.5	1241.5	24.4
1242.0	1252.0	24.5
1252.5	1262.5	24.6
1263.0	1273.0	24.7
1273.5	1283.5	24.8
1284.0	1294.0	24.9
1294.5	1304.5	25.0
1305.0	1315.5	25.1
1316.0	1326.0	25.2
1326.5	1337.0	25.3
1337.5	1347.5	25.4
1348.0	1358.5	25.5
1359.0	1369.5	25.6
1370.0	1380.5	25.7
1381.0	1391.5	25.8
1392.0	1402.5	25.9
1403.0	1413.5	26.0
1414.0	1424.5	26.1
1425.0	1435.5	26.2
1436.0	1447.0	26.3
1447.5	1458.0	26.4
1458.5	1469.5	26.5
1470.0	1480.5	26.6
1481.0	1492.0	26.7
1492.5	1503.5	26.8
1504.0	1514.5	26.9
1515.0	1526.5	27.0
1567.0	1538.0	27.1
1538.5	1541.0	27.2

## 10.5 Printhead Replacement and Alignment

If the printhead on the Model 1200R should require replacement, first make note of the Odometer Length Count and Dot Count as outlined in Section 8.7. These numbers should be recorded in the table following this section so that valid usage figures on the replacement head can be determined at a later time if required. These numbers should be reported to the factory as well.

Before removing the printhead, power-down the plotter. The printhead is fixed to the spring-loaded carrier bar with a total of 4, #10 socket-head screws near in the center and 2, M3 phillips-head screws. Loosen all of the screws fully, but leave them in their holes. With one hand steady the printhead and with the other, raise the printhead locking lever. The carrier bar should then lift up clear of the printhead. The printhead can now be disconnected from the power and data wire harnesses and taken away. The mounting screws can be left in their holes in the carrier bar.

On the replacement printhead, note and record the labelled resistance value on the printhead. These values should be used to set the Print Power Supply according to the value derived from Table 11 and Sections 8.5 and 8.6. It is safe to make this adjustment with the plotter powered-up and the printhead disconnected. Make this adjustment before connecting the new printhead.

**Caution:** The printhead is subject to damage from electrostatic discharge. Exercise proper grounding techniques while working on the printhead, and do not touch the connector pins when handling it.

Mount the replacement printhead to the carrier bar using the screws removed earlier. Get all screws started first without tightening. Observe the alignment of the rear edge of the carrier bar with the aluminum section of the printhead. Maintain this alignment as the mounting screws are tightened fully. Make sure that the black heater feed wire is fastened to the carrier bar at the left-hand mounting screw. With power off, connect wire harnesses to printhead.

Printhead alignment is an iterative process which requires proper setting of the following:

- Horizontal printhead in/out position using tie rods
- Pressure adjustment using adjustment of ball plunger(s).

Loosen the set screw securing the ball plunger in the tapped holes of the carrier bar. We recommend to initially set the ball plunger with approximately 1/8 inch (3 mm) between the cam in its position of full engagement and the ball plunger housing. The most useful test pattern for head alignment is the "Half Tone" pattern, as described under "Service Mode Test Patterns" (Section 10.3). It may also be useful to limit the output speed to approximately 0.5 inch/sec (13 mm/sec) by use of the "Chart Speed Limit" menu item (Section 7.3) or Controller Board DIP Switch S3 (recommend stations 3,4,5 On; 1,2 Off).

Note the 2 adjustable tie rods between the printhead assembly and chassis plate which set the in/out position of the printhead on the platen.

Note: For adjusting all tie rods:

- To lengthen tie rod, turn the adjustment stud clockwise (facing from front).
- To shorten tie rod, turn the adjustment stud counterclockwise (facing from front).

The first step of alignment is to get printhead horizontal position correct using the tie rods. The best position is one which achieves close contact for all dots in the printhead against the platen roller surface (separated, of course, by the thermal media). Note that all tie rods are equipped with jam nuts, which must, of course, be loosened prior to adjustment. It is important to keep the jam nut on the center tie rod closest to the printhead carrier tight when conducting a test, because this can affect head alignment. The other jam nuts can be kept loose for the duration of the alignment procedure.

The recommended procedure is to observe the Self Test printout while "walking" the end of the printhead in and out by turning the right-hand tie rod. Use the result to determine any change which should be made to the center tie rod.

- If the right-hand edge fades before the left while walking the right-hand end out (tie rod turning clockwise), try shortening the center tie rod.
- If the right-hand edge fades before the left while walking the right-hand end in (tie rod turning counterclockwise), try lengthening the center tie rod.
- Proper setting for the end tie rod is in the "middle" of the zone of acceptable operation.

Do not attempt to get printing perfect on the first pass of this procedure until printhead pressure has been adjusted.

If the Half-Tone pattern exhibits light areas near the edges of the plotted field, it may be helpful to insert shim stock .005-.020 inch (0.1-0.5 mm) thick between the carrier bar and the printhead to improve contact in these areas. Further improvement can be gained as necessary by increasing the printhead pressure spring by raising the plunger body (turn counterclockwise). Always attempt to make this pattern uniform with minimum contact force, as an excess of force can degrade horizontal line straightness. In no case should the ball plunger threaded housing contact the cam in its locked position. The cam should bear only upon the spring-loaded plunger.

When acceptable results have been achieved, tighten all tie-rod jam nuts. Lightly tighten the setscrew securing the ball plunger (this is a soft tip setscrew).

<p><b>Important:</b> After completing service functions, always return Processor Board DIP Switch Station 6 to the Off position.</p>
--

**Note:** This table following should be filled in if a printhead gets replaced. A copy should be forwarded to Atlantek with the removed printhead. Consult Model 1200R manual Section 8.7 for instructions on accessing "Odometer Count Report".

Date:	
Plotter Serial No:	
Printhead Removed -- Serial No:	
Line Count "LnCnt"	
Dot Count 1 "DCt1"	
Dot Count 2 "DCt2"	
Dot Count 3 "DCt3"	
Dot Count 3 "DCt4"	
Replacement Printhead -- Serial No:	

Date:	
Plotter Serial No:	
Printhead Removed -- Serial No:	
Line Count "LnCnt"	
Dot Count 1 "DCt1"	
Dot Count 2 "DCt2"	
Dot Count 3 "DCt3"	
Dot Count 3 "DCt4"	
Replacement Printhead -- Serial No:	

## 10.6 Controller Board Sensor Adjustment

In some plotters, the Controller Board may be equipped with a potentiometer for the purpose of adjusting the media-present monitor channel for optimum reliability over a broad range of different media which may be used in Atlantek plotters. If present, this potentiometer is located near Media Sensor connector J9. This must be adjusted whenever a media sensor or Controller Board is changed in the field.

### 10.6.1 Principle

The media monitoring function is performed by a reflective optical sensor (Optek OPB704) mounted in the front edge of the guide extrusion below the platen roller. This sensor can be seen recessed in a hole in this piece near the middle of the web span. During normal operation, the media web is drawn taut in front of this sensor, thus providing sufficient optical reflection to generate a signal which can be sensed by the board microcontroller i.c.. This sensor component includes both emitter and detector elements. Since it operates in the infrared-band, it comes equipped with a visible-band light filter to minimize the effects of ambient lighting. The sensor detector element is designed to pass a current level proportional to the light amplitude sensed. A simple resistive element changes this current to a voltage signal for direct input to a logic gate (U33, 74HC14):

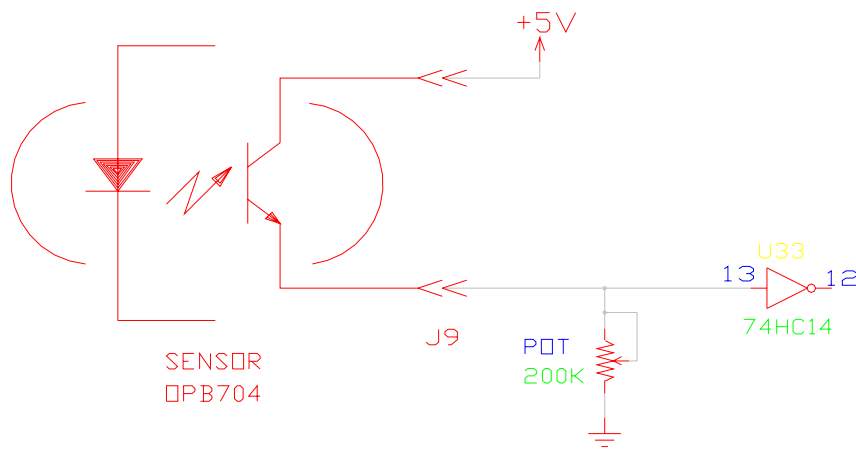

It is the nature of these sensors to exhibit a wide unit-to-unit variation in current output for a given reflectivity. For this reason, along with the wide variety of media which may be employed in Atlantek plotters, the board is equipped with a potentiometer which may be adjusted to normalize the sensor voltage response and thus obtain reliable media sensing. Recommended signal levels into U33 are:

- "Light" condition (media present), 3.5 V, min
- "Dark" condition (media out), 1.0 V, max

The best way to set the media sensor adjustment at a plotter site is to monitor the sensor output voltage with each media type in use with this plotter and to adjust the potentiometer for a safe "light" condition voltage with the least reflective media in use. Note that infrared wavelength reflectance for a material does not necessarily track with eye-observed "whiteness". Some clear thermal films are in fact more reflective at infrared than white thermal paper.

If the specific media types to be used with this plotter are not known or are unavailable, Atlantek provides a sample of translucent thermal film (Kanzaki KPL100) which is known to be less in reflectance than most other thermal media, and so may be used as a "worst case" media for adjustment purposes. Other media should yield a higher sensor output voltage. One caution to be observed in this case is that since the sensor system is forced to operate at greater sensitivity, there is an increased chance of incorrect sensor response to ambient light, particularly from sunlight or incandescent sources. Therefore always check both light and dark levels when making this adjustment.

#### 10.6.2 Procedure

1. Prepare sample(s) of the media to be used for this adjustment. The samples should measure a minimum of 11 inches (28 cm) long and 2 inches (5 cm) wide. Before cutting this media off, identify the sample as to its thermal-coated side according to the known roll winding configuration. It also possible to use media directly in roll form as it would be commonly installed in the plotter; but in this case there should be no more than 2 ft (60 cm) material remaining on the roll core, to insure that the test is conducted at minimum roll diameter.
2. Open plotter case and install sensor and/or Controller Board as required for this site.
3. Using a "DIP Clip" or similar device, attach a voltmeter between Controller Board U33 pin 13 and ground (U33 pin 7, or TP8 on board). Locate media sensor adjustment potentiometer near sensor connector J9.
4. Lift the printhead lever. Power-up plotter and allow it to go through its initialization sequence.
5. Install media sample. Insure that the thermal-sensitive surface faces toward the sensor, as is the case for normal operation. With translucent/transparent films, the thermal-sensitive side usually exhibits less gloss than the non-sensitive side.
  - If the media sample is attached to its core, thread the web normally and pull taut around the sensor.
  - If the media sample is loose, thread the sample as it would normally reside and clamp one end between the printhead and platen using the printhead locking lever. Then pull the sample taut through the threading path, against the sensor, and in back of the empty media core installed in its normal position. The spring-loaded "flapper" will help to hold the media sample tight and in position.

6. With the media taut and in position, read the voltmeter and adjust the potentiometer to obtain a reading of 3.5 V absolute minimum, or preferably 4.0 V. If sufficient voltage cannot be attained, then either:
  - Do not attempt to perform media sensing with this material. If the KPL100 film sample alone yields this response, but is not required by the plotting application, attempt to perform the adjustment using the actual media types in use at this site. or,
  - The sensor has insufficient response for this material and must be replaced.

See Item #9 for further advice in case of insufficient signal level.

7. Test all available media types, and repeat Item #6 to obtain recommended response with all types.
8. Remove media from mechanism. Voltmeter reading should be 1.0 V, max. If this condition is not met, attempt to identify the source of light which might be contributing to this. If nothing can be done, the adjustment must be changed to give a safe media-out "dark" sensor level. In this case, it may be impossible to operate normally with some media type(s). See Item #9.
9. If the sensor response for a given media type is insufficient to achieve a reliable "light" signal level, apply a paper stick-on label over the sensor hole to mask the sensor, or invoke the "Media Sensor: Disable" menu feature if plotter is so equipped.

## 10.7 Troubleshooting

Table 12 - Troubleshooting Guide

Symptom	Possible Causes	Recommendations
No lamps or LCD Message at Power Up.	No AC Power source. Defective Line cord. Voltage configuration incorrect. Fuse blown. Defective Power Switch. Defective Logic Power Supply. Display not connected to Processor Board.  Processor or Controller Board defective or not connected to Logic Power Supply.	< - Perform Isolated Controller Test (see Section 10.7.2).
Low/High Temp Lamps light at Power-Up Initialization and media advances after 15 sec. but LCD does not report correctly (see Section 4.7).	Processor Board not connected to +5V logic power.  Defective Display. Defective Processor Board.	
Error Code "0200" and "Cntlr Comm Err" listed at Power-up Test Report. (see Section 10.7.3)	Controller Board not connected to +5V logic power or Processor Board.  Defective Controller Board. Defective Processor Board.	< - see Section 10.7.3  < - Perform Isolated Controller Test (see Section 10.7.2).
Mechanism Stall Alarm at Power-up Initialization with no visible media advance.	Defective Motor Power Supply. Motor not connected to Controller Board. Defective Controller Board (motor drive). Defective Stepper Motor. Belt broken. Platen or Media Jammed.	
Mechanism Stall Alarm at Power-Up Initialization but media advances properly (about 3/8 inch).	Defective Rotation Sensor or cable. Sensor not aligned correctly with platen shaft sprocket. Defective Controller Board.	Check LED2 on Controller Bd. during advance (see Section 10.7.1).
Intermittent Mechanism Stall Alarm during Self Test or Host Plot actuation.	Defective Rotation Sensor or cable. Media gripped too tightly by Drag Arm end restraints. Excessive friction in Platen Roller bearings or Jackshaft. Defective Controller Board.	Test by disabling Stall Sense. Apply JP4 on Controller Board. (see Section 8.3)

Media-Out Alarm even though media is installed.	Media Sensor not plugged into Controller Board. Defective Media Sensor or cable. Media Sensor setback distance incorrect. Improper Sensor adjustment on Controller Defective Controller Board.  Clear Media in use (see Section 4.6.2).	Observe LED4 on Controller Bd (see Section 10.7.1)  < -see Section 10.6  < - Disable Media Sense thru User Configuration menu.
Host indicates that Plotter is Busy, Offline, of Out-of-Media.	Plotter not in Online state. Host data cable poor connection. Incorrect interface configuration. Defective host data cable. Defective Processor Board.	
Host Plot data garbled but Self Test plot okay.	Incorrect plot/print byte count configuration. Defective host data cable. Defective Processor Board.	< - see Sections 7.5- 7.8
No plot/print in both Self Test and Host Plot/Print.	Wrong media in use. Media installed incorrectly. Power feed wires not installed between Print Power Supply, Power Distribution Board, and Printhead. Defective Print Power Supply. Defective Power Distribution Board.  Power Distribution Board not connected to Controller Board.	< -If this is so, you will not hear relay click at Power-Up.
Light plot/print in both Self Test and Host Plot/Print.	Wrong media in use. Energy level too low for media. Incorrect adjustment of Print Power Supply Defective Print Power Supply. Defective Power Distribution Board.	Try Zig-Zag self-test pattern and do test below.
Entire plot width drops out in horizontal band when plotting full width Zig-Zag pattern.	Defective Print Power Supply. Defective Power Distribution Board	
Vertical bands (gaps) in plotted output for both Self Test and Host Plot.	Dirt on Printhead. Poor quality media. Printhead misaligned. Defective Printhead. Defective Controller Board.	< - see Section 10.5
Periodic plot dropouts approximately every 4 inches in vertical axis.	Energy Level setting too Low. Printhead misaligned. Platen roller gouged.	< - see Section 7.1 < - see Section 10.5

Incorrect chart length calibration.	Media slipping. Platen defective. Incorrect drive belt pulleys installed.	
Horizontal density "banding" noticed during start/stop plotting conditions.	Belts loose.	Try reducing maximum speed limit to reduce variation (see Section 7.3).
Media tracking problems.	Poor quality media. Drag arm side restraints not adjusted correctly. Printhead pressure too high. Media incorrectly mounted.	< - see Section 4.2  < - see Section 10.5 < - see Section 4.2
Plotter output speed is lower than expected.	Energy Level set too High. Speed Limit invoked needlessly. Host data transfer rate is limiting speed. High Temp shutdown condition is in effect. Controller Board S3 switch changed.	< - see Section 7.1 < - see Section 7.2  < - see Section 4.4 < - S3.1-3.5 should all be Off.
Low Temp lamp does not go out.	Plotter being operated in cold environment. Broken feed wire to Printhead background heaters. Defective Print Power Supply. Defective Power Distribution Board (Heater control Relay).  Power Distribution Board not connected to Controller Board.	Check LED5 on Controller Bd (see Section 10.7.1).  < - If this is so, you will not hear relays click at Power-Up.
High Temp lamp goes on during plots.	Plotter being operated in hot environment. Ventilation ports blocked. Plot data load and/or speed too high.	
Failure to retain Configuration through power-down period.	Processor DIP Switch Station 8 is On.	Sta.8 should be Off.
"NVRAM Error" message at Initialization	NVRAM battery depleted.	Call factory for replacement device.
"Firmwre Mismatch" message at Initialization	Improper ROM's installed in Processor or Controller Boards.	

<p>"Ilgl Sensr Mask" message at Initialization</p> <p>or</p> <p>"Halt:IlegSnsMask" message anytime</p>	<p>Improper masking of both Media Sense and Rotation Sense.</p>	<p>Remove JP4 to unmask Rotation Sense.</p> <p>Use menu to unmask Media Sense (see Section 7.4).</p>
<p>One of the following messages:</p> <p>"Halt: Intfce RLTER"</p> <p>"Halt: Intfce RFFED"</p> <p>"Halt: Intfce REOTR"</p> <p>"Halt: Intfce CLEAR"</p>	<p>Remote command input line does not obey "READY" line handshake.</p>	<p>Defective host system cable or interface driver hardware.</p> <p>Incorrect interface configuration (Differential / TTL).</p>

### 10.7.1 Controller Board Indicators

The 3 optical sensors are monitored by logic on the Controller Board. These states are available visually for quick reference. This may be useful in the case of problems with the sensors.

Note as shown below the rectangular array of 4 white modular telephone connectors in the lower right-hand corner of the Controller Board, as viewed from the front of the plotter with the front/top cover removed. Three of these are utilized for the sensors on the 1200R plotter. The silk screen on the Controller Board gives a key to their function.

Note as shown below the rectangular array of 4 white modular telephone connectors in the lower right-hand corner of the Controller Board, as viewed from the front of the plotter with the front/top cover removed. Three of these are utilized for the sensors on the Model 1200R plotter. The silk screen on the Controller Board gives a key to their function.

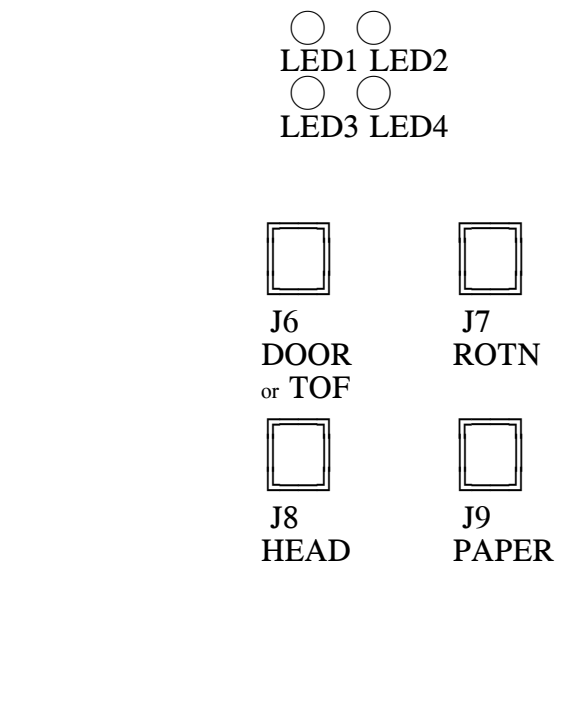

Note the presence of the unused connector (J6). This is provided for use with a "Top-of-Form" cue mark sensor in plotters which are equipped for form registration. Also note just above (R-type chassis) these connectors resides an array of 4 LED indicators. The indicators give the current logical light/dark status seen for each sensor in its analogous position in the connector array.

- An indicator being On implies that the sensor is in the "light" state (ie. reflective surface "seen" or gap not blocked).
- An indicator being Off implies that the sensor is in the "dark" state (ie. reflective surface "not seen" or gap blocked).

The current state of the Heater Relay control signal being output to the Power Distribution Board is visually readable by the state of LED5, located near the top right-hand corner of the Controller Board as viewed from the front of the plotter (R-type chassis).

- The indicator is On when the heaters are intended to be On (relay coil Off).
- The indicator is Off when the heaters are intended to be Off (relay coil On).

### 10.7.2 Controller Board Isolated Test

One useful diagnostic technique allows the plotter to be tested with the Processor and Controller Boards isolated. In this condition, the Controller is configured to generate its own data internally, without need for printhead data to be supplied from the Processor as is the normal case. This allows the wellness of the Controller-to-Printhead data channel to be established. If a problem arises in which the Processor Board is suspected, this test can help confirm this.

To perform:

1. Power-down plotter.
2. Remove the Processor to Controller Board interconnecting cable (40 wire ribbon).
3. Apply shunts to jumper locations JP5, JP6, and JP11 on the Controller Board.
4. Insure that media is installed correctly, the transport mechanism is free, and the printhead locked down.
5. Power-up plotter. Since the boards are isolated, pay no attention to the Display. The 15 second initialize period should elapse, then the media should advance approximately 3/8 inch (9 mm).
6. Momentarily press switch S1 on the Controller Board. A test plot should then be produced across the entire printhead, consisting of a pattern like the self test "Zig-Zag" pattern but smaller. The plot will come out very slowly, about 0.1 inch/sec (2.5 mm/sec). The plot will be performed under Energy Level 1 conditions, so that slow media may not blush completely. If this pattern appears okay, it is reasonable to assume that the Controller, Printhead, Power Supplies, and Motor are working properly. Press S1 again to stop the test plot.
7. At the completion of the test, power-down plotter, and remove the shunts applied in Step 3. If placing the plotter back into service, reconnect the Processor Board to the Controller Board.

### 10.7.3 Processor Board Power-Up Test Error Codes

There are a series of tests executed by the Processor Board to determine its own internal wellness. The result of these tests is displayed as part of the Initialization State display sequence (Section 6.1.2) and the Configuration Service Menu, Power-Up Error Code (Section 8.9). If any problem was found is displayed as a specific bit in a 4 hexadecimal digit error code number. For each test that fails, a 1-valued bit is inserted into a 16 bit error code word of 0000<sub>hex</sub>. The following table summarizes the error codes and the bit assignments for each test.

**Table 13 - Power-Up Error Codes**

Error Code (Hexadecimal)	Bit Position	Test conducted
0001	0	Processor Board ROM Checksum Test
0002	1	Static RAM Test
0004	2	Controller Board ROM Checksum Test
0010	4	NVRAM Read/Write Test
0020	5	NVRAM Valid Pattern Test
0040	6	DMA Controller Test
0080	7	Parallel Port Test
0200	9	Controller Board Communications Test
0400	10	Processor/Controller Firmware compatibility
0800	11	Illegal sensor masks (Media & Rot'n)

Be aware that multiple errors shall have the effect of adding together the error codes associated with each failed test. For example, if both the "NVRAM Read/Write Test" and "NVRAM Valid Pattern Test" were to fail (as would be the case if the NVRAM were completely non-functional), and other tests pass, the resultant Error Code would be "0030"(hexadecimal), indicating that Bits 4 and 5 were set due to failed tests.

This feature might be especially useful for the purpose of indicating errors in the Controller Board Communications Test. This would occur if the Controller Board was non-functional, or possibly simply not connected to the Processor Board.



**Figure 7 -- Model 1200R Plotter Wiring Diagram**

This page is intentionally left blank.