



## Printrex 812

## Contents

- Overview .....2
- Installation .....3
  - Connecting the Data Cable .....4
  - Connecting Power ....4
- Operation .....5
  - Power Up and Power Management ...5
  - Loading Paper .....5
  - Advancing Paper .....6
  - Forms Mark .....6
  - Self Test .....6
  - Tearing Paper .....7
  - Error Codes .....7
  - Printer Driver .....8
- Specifications .....9
- Printrex Warranty .....10

The Printrex 812 is designed for use with Mobile Data Terminals in motor vehicles. It operates directly from the vehicle power supply and connects to either 12 volt DC or 24 volt DC systems.

The 812 replaces the earlier 810 MV, 810 ML, 820 MV and 820 ML. The data interface is USB 2.0 with IEEE 1284 (Centronics compatible) also available for legacy systems.

It is packaged in a polyethylene case having no sharp corners and is highly resistant to impact damage. A Quick Release option permits almost instantaneous replacement of a printer in the field.

The Printrex 812 can be placed on a table, securely attached with shock mounts or can be attached to a vertical surface using the Quick Release Plate. See Figures 2 and 3.



**Figure 1. Printrex Model 812 Mobile Printer/Plotter**

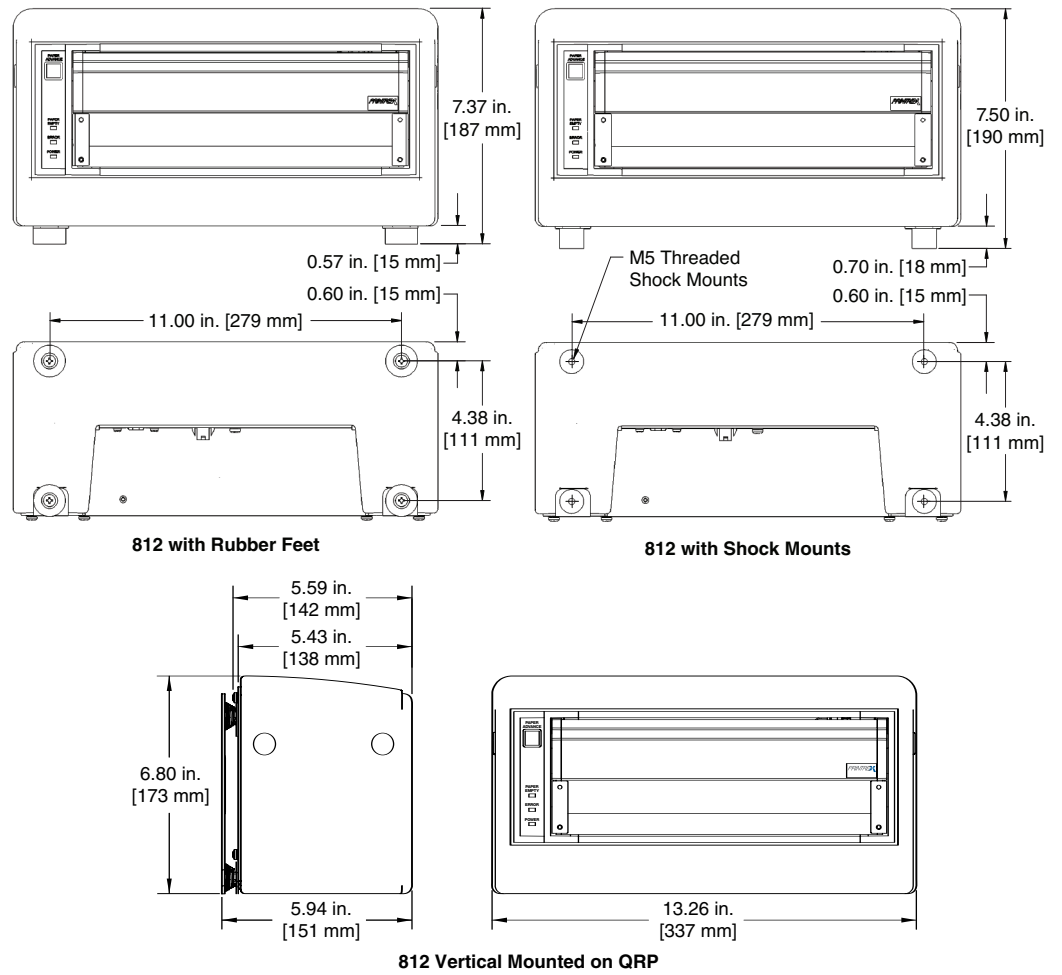

**Figure 2. Printrex 812 Dimensions**

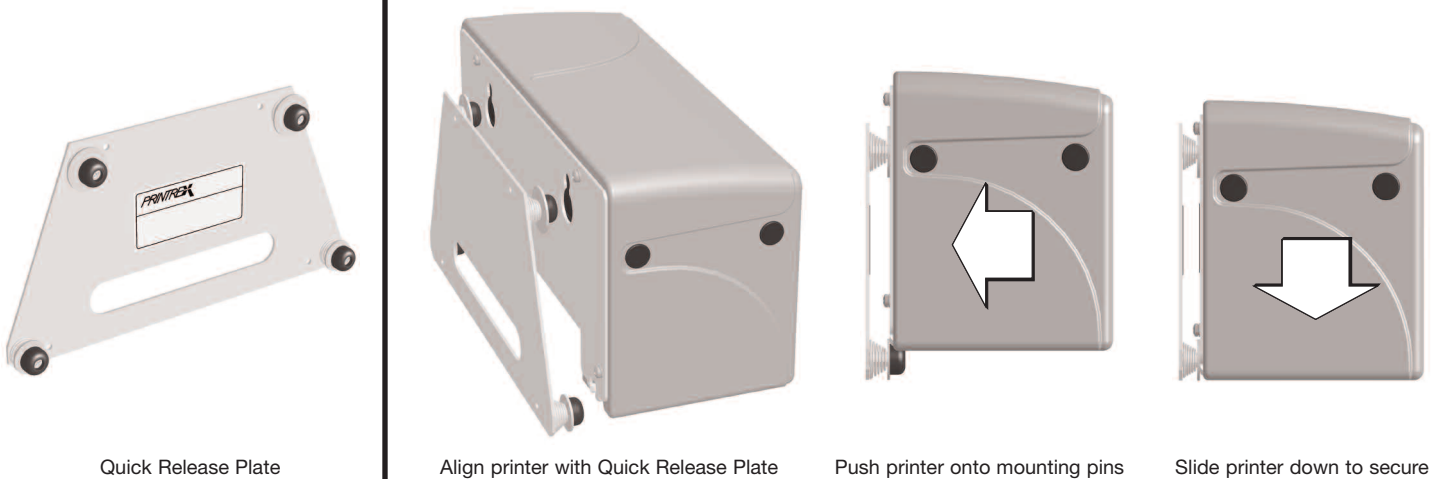

**Figure 3. Installing the 812 on the Quick Release Plate**

## Connecting the Data Cable

## Connecting Power

It is important to use high quality cables. If using the parallel port, the cable should be marked "IEEE 1284" and it is best to connect the data cable before connecting power. The USB cable can be connected with printer power on.

Power is supplied through a four pin connector. See Figure 4. Pins 1 and 2 are + power and pins 3 & 4 are the ground return. Power can be supplied from either +12 volts DC or +24 volts DC.

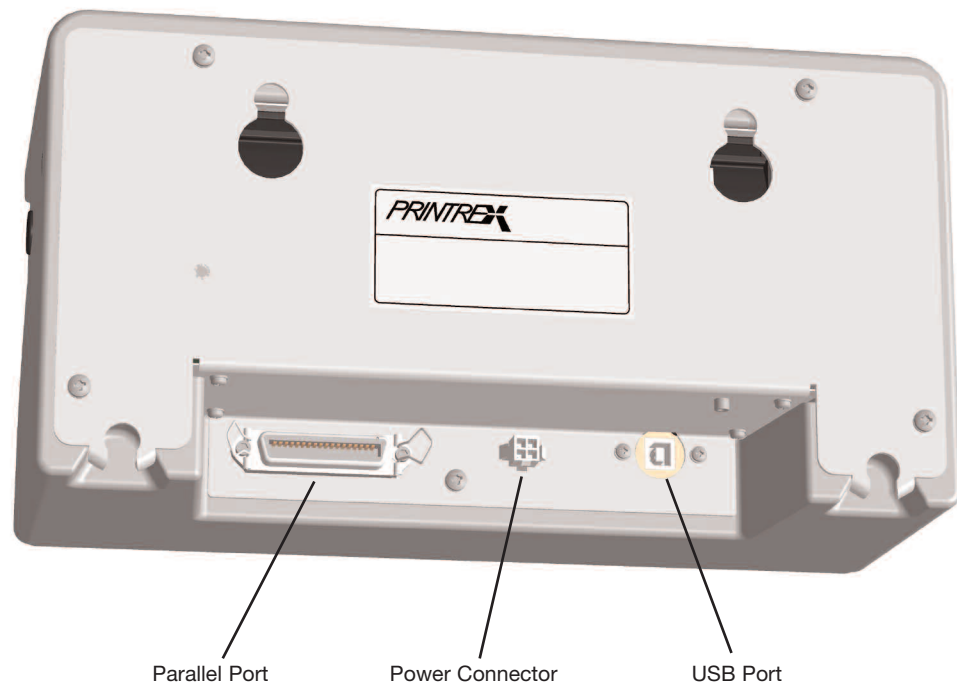

**Figure 4. Data and Power Connections**

## Power Up and Power Management

## Loading Paper

The Printrex 812 does not have a power switch so power is applied when the host system power is on. When the printer is idle with no print commands from the host or no paper feed input from the front panel for 5 minutes, it goes into “suspend” mode to reduce demand on the vehicle power system. A print command through the interface or from the front panel paper feed switch restores the printer to full activity. The front panel power indicator is **NOT LIGHTED** in suspend mode.

Loading paper is extremely simple because it does not have to be threaded or aligned. To load the paper (see Figure 5):

1. Unlock the door of the printer by pressing on the open circles printed on the two latches at the lower corners of the door. Pull up on the latches to open the door.
2. Remove the paper carrier from the printer and remove the paper rod from the holder. Slip the empty core off the rod.
3. Slip the paper rod through the core of the new paper roll and install the paper roll on the carrier so the paper feeds from the top of the roll toward the front of the holder as shown in the figure and on the paper carrier. Feed a few inches of paper from the roll so it will extend over the platen after insertion into the printer.
4. Insert the paper carrier in the printer and close the door. Press on the solid circles printed on the door latches to lock them.
5. Tear off the extra paper. There are two tear bars, one on the bottom of the front door for tearing up and one on the printer housing for tearing down. Pull up or down and slightly to the right or left to tear paper.

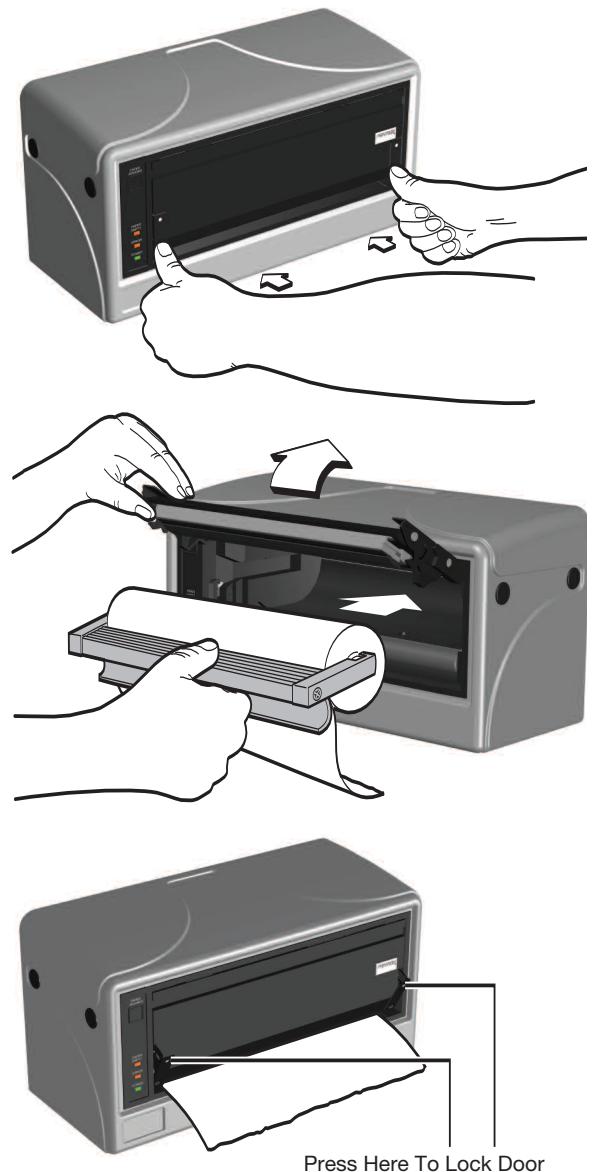
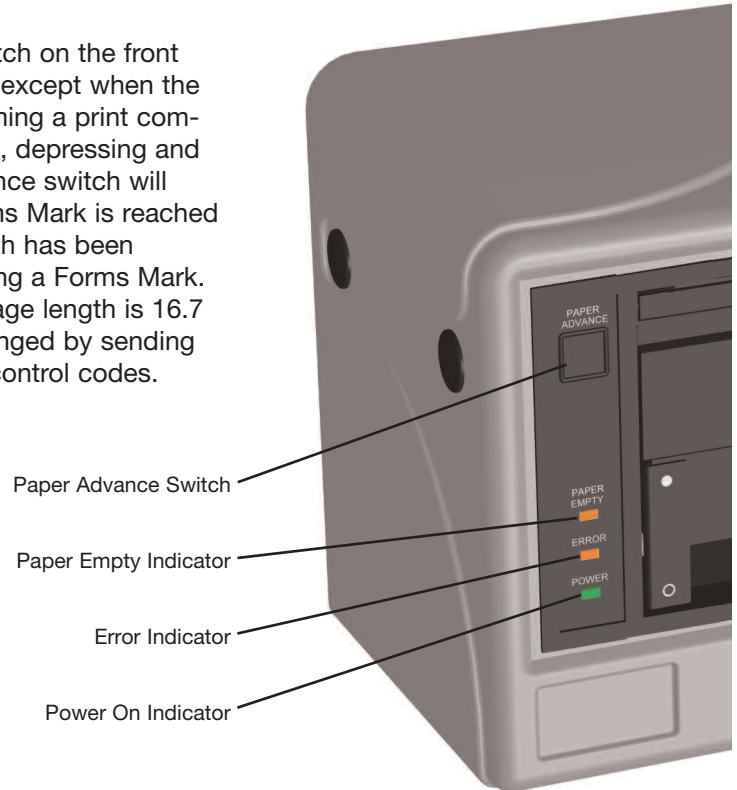

**Figure 5. Loading Paper**

**CAUTION:** The door should be unlatched during storage to avoid temporary flat spots on the platen.

## Advancing Paper

The Paper Advance switch on the front panel is active any time except when the printer is “Busy” performing a print command. At any other time, depressing and holding the Paper Advance switch will move paper until a Forms Mark is reached or the logical page length has been reached without detecting a Forms Mark. The power up default page length is 16.7 inches. This can be changed by sending the appropriate printer control codes.



**Figure 6. Front Panel Controls and Indicators**

## Forms Mark

The 812 recognizes a preprinted forms mark on the back of the paper and can position the paper so pages can be made a consistent size and preprinted forms can be used. Perforated paper wound on a roll can be used.

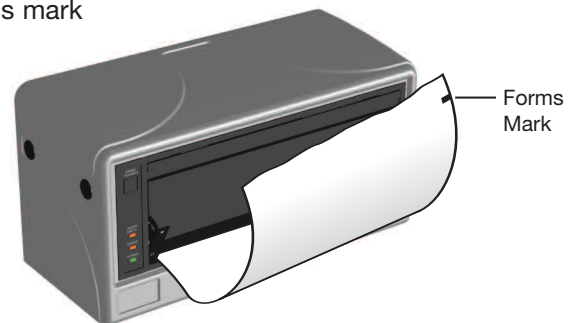

**Figure 7. Forms Mark Location**

## Self Test

Printer Self Test is initiated by holding the Paper Advance switch down while power is turned on. The switch can be released after printing begins. The Self Test print out will list the model number, controller software identification, a graphics pattern and the character set repeated in 10, 12, 17 and 20 pitch. It will then terminate.

There are times when it is useful to have the test pattern repeated. If the Paper Advance switch is held while the first test pattern is finishing, the printer will enter a repeating self test mode where the entire test pattern is repeated until the unit power is turned off.

## Tearing Paper

Tear bars are located on the bottom of the front door for tearing paper up and on the printer housing for tearing paper down. Pull up or down at a 45° angle and slightly to the right or left to tear the paper.

## Error Codes

Printer error conditions are shown by the Error Indicator on the Front Panel. This is in the form of a two digit error code expressed as a series of long flashes (for the tens digit) then short flashes (for the ones digit). The tens digit flash is twice as long as the ones digit flash. Example: One long flash followed by two short flashes for an error code of 12 indicates Door Open.

The Error Indicator will continue to flash while the error condition exists. Refer to the following table for the error codes and their meaning.

<i>Error Code</i>	<i>Name</i>	<i>Description</i>
11	Paper Empty	There is no paper in the printer. Cleared by loading paper.
12	Door Open	One or both of the door latches are unlatched. Cleared by closing both latches.
21	Under Voltage	Print head voltage is less than 8.5 volts. Cleared when voltage is above 9 volts.
22	Over Voltage	Print head voltage is above 27 volts. Cleared when voltage is below 26.5 volts.
24	Over Temperature	Print head is above 55°C. Cleared when print head cools below 50°C.

The Printrex 812 does not have an under temperature error. The low operating temperature is specified as -10°C to ensure good image quality. The 812 is often used in emergency services where it is necessary to print, even with reduced image quality but it must be recognized that the print quality may be less than optimal. When printing is initiated, the print head temperature will quickly reach the normal operating range due to energy used in printing.

## Printer Driver

Most Printrex printers/plotters are placed in service as part of a system from an OEM (Original Equipment Manufacturer). They will usually have the printer driver software installed in the host system and no additional effort is required by the user.

In those cases where the printer is not being supported by an OEM, the printer driver for Windows 2000/XP and Vista can be downloaded from the Printrex web site.

1. Acquire driver

Go to Printrex website at [www.printrex.com](http://www.printrex.com)  
Click on "Support"  
Click on "Drivers"  
Click on "Download Windows 2000/XP/2003 drivers for"  
Click on "Download Driver Files..."  
Click "Save" when prompted in the Download box  
Select file location on computer (suggest Desktop)

2. Expand compressed (zip) file

Double click on zip file downloaded above (filename format: prx\_wxp-relxx.zip)  
Select "Extract"  
Directory to place extracted files can be selected in "Extract to:" field (defaults to same place as the zip file is located)  
Click on "Extract"

3. Plug in printer

Connect +12 or +24 volts DC to the printer  
Connect a USB cable from the printer to the computer

4. Plug and Play

The computer will pop up a message saying new hardware found  
Click on this message and follow "Found New Hardware Wizard" instructions  
If the driver can not be found automatically, enter directory where previous files were extracted and select the "Prxprint.inf" file

5. Complete installation

Confirm paper is loaded into the printer and the door is closed  
Select "Print test page" to verify correct driver installation

Printrex at this time does not distribute filter files for Unix or Unix type platforms. Users of applications under these systems should contact the application supplier for assistance.

## Print Speed

Print speed is 1 inch/second with input voltage of 12 volts or higher and temperature in normal operating range. As voltage and/or temperature decrease, the print speed will be modestly reduced to maintain good image quality. Printing is inhibited if voltage is below 8.5 volts. Low temperature does not inhibit printing but below the specified lower limit of -10°C, image quality may be degraded. The 812 is often used in emergency services where it is necessary to print, even with reduced image quality but it must be recognized that the print quality may be less than optimal. When printing is initiated, the print head temperature will quickly reach the normal operating range due to energy used in printing.

## Input Power Requirement

9 volts DC to 32 volts DC

## Mechanical Specifications

Weight 7 pounds (3.2 kg)

Shipping weight with paper 12 pounds (5.5 kg)

Size

13.26 inches (33.7 cm) wide

5.5 inches (14 cm) deep; 5.94 inches (15.1 cm) with Quick Release Plate

6.8 Inches (17.3 cm) high without feet or shock mounts

Rubber feet add 0.57 inches (1.5 cm)

Shock mounts add 0.70 inches (1.8 cm)

## Media Mechanical Specification

Width 8.75 inches (222 mm) – 8.5 inches (216 mm) is an available option

Maximum Roll Diameter 2.6 inches (66 mm)

Core I.D. 0.5 Inch (13 mm)

## Environmental

Operating temperature -10°C to 50°C (14°F to 122°F)

Storage temperature -40° to +60°C (-40° F to 140°)

Dust, spray and splash rated IP 54

## Regulatory

e mark EMC directive 2006/28/EC

RoHS compliant

Cispr 22 Radiated and Susceptibility, Class B

FCC Part 15, Class A

PITO AES5, Issue 10

Flammability rating UL94HB

Printrex products are warranted to be free from failures due to defects in material and workmanship for twelve (12) months from the date of purchase. During this 12 month period, Printrex will, at its sole discretion, replace or repair at no charge the product, which in its opinion, is defective.

If the product has been modified without Printrex's consent or if the failure is the result of misuse, abuse or misapplication, Printrex warranty obligations are void.

**Consumables Warranty:** Printrex warrants that the thermal print head will be free from defects for Expected Life of the print head but not more than one (1) year from the date of purchase. The Expected Life of the print head is considered to be the lesser of, A) fifty (50) kilometers of delivered media or B) one hundred million (100,000,000) pulses of an individual print element (approximately 12.7 kilometers of converted printout for any given print element).

Except as expressly provided above, the hardware and accompanying written materials (including this User's Guide) are provided "as is" without warranty of any kind, including the implied warranties of merchantability and fitness for a particular purpose, even if Printrex has been advised of that purpose. In no event will Printrex be liable for any direct, indirect, consequential or incidental damages arising out of the use of or inability to use such product even if Printrex has been advised of the possibility of such damages.

## **Printrex, Inc.**

276 East Gish Road  
San Jose, California 95112-4703

Telephone: 408 573 1200  
Facsimile: 408 573 1600  
[www.printrex.com](http://www.printrex.com)

Information in this document is subject to change without notice and does not represent a commitment on the part of Printrex, Inc. No part of this manual may be reproduced in any form for any purpose other than the purchaser's personal use or internal use by other members of the purchaser's organization without the written permission of Printrex, Inc.

Printed in the United States of America  
Copyright 2007 by Printrex, Inc.  
Document number 1028-0098  
August 2007