

820 DL

THERMAL PRINTER/PLOTTER

CONTENTS	1	Installation	2
	2	Preparation for Operation	6
	3	Errors and Error Handling	10
	5	Host Control - On Line Mode	11
	4	Performance Specifications	16

Printrex produces high performance printers/plotters for Original Equipment Manufacturers.

These printers feature an innovative, integrated paper handling system that allows the user to reload paper in seconds without any threading or alignment. The operator simply inserts the paper carrier, closes the door and is ready to print.

Special configurations of hardware and software are offered to meet the unique requirements of demanding applications.



FEATURES

Multiple Configurations- The 820 DL is available in a variety of configurations to meet the requirements of the OEM market.

- Complete printers with cover set and power supply.
- Panel mounted units that require +5 Vdc and +24 Vdc.
- Printer and power supply configured on a chassis with front panel for installation in a 19-inch rack.

Media Flexibility- The 820 DL can print/plot on a variety of media. They can be configured for standard rolls of thermal paper with either 8.5 inch or 8.75 inch widths, fan fold paper and thermal transparencies.

Software Drivers- Drivers for Windows®, Windows® 95 and Windows NT™ are standard.

Interface Options- The standard interface is Centronics-type parallel with interface converters available for RS 232 or 20 ma current loop inputs.

Character Mode- The character set comprises 224 alphanumeric and graphic characters. They can be printed at 10, 12, 16.7 or 20 characters per inch.

Plot Mode- Bit mapped graphics can be printed at 100 or 200 dots per inch. Different paper speeds can be selected to match the input data rate for optimum plot speed.

Regulatory Certifications- Configurations that conform to the most common regulatory requirements are available. They meet the requirements of UL 544, CSA 22.2 and IEC 601-1 for medical equipment. They conform to the EMC

(Electromagnetic Compatibility) requirements to carry the CE Mark.

Text Mode Controls- Characters can be printed double wide and double high, bold, normal or reverse image at 6.25 or 12.5 lines per inch. They can be printed normal or inverted.

Dynamic Sensitivity Control- Maintains optimum print intensity over a wide range of printing conditions.

8K Byte Data Buffer- Allows the host system to dump to the printer.

Intensity Control- Different levels of darkness can be selected to adjust to different media sensitivity.

Microprocessor Watch Dog Protection- Provides protection for high cost components in the printer.

Brown Out Protected Electronics- Provides additional protection during low line conditions.

INSTALLATION OF PANEL MOUNT PRINTERS

Mounting

As shown in Figure 1, the panel-mount versions have a 0.10-inch (2.54 mm) front mounting flange and four mounting holes (two on each side) threaded for either #10-24 or M5 metric screws as specified. The printer may be mounted with its front panel rotated 30° downward through 90° upward from the true vertical.

Panel Mount Power Requirements

+5 Logic Supply:	+5 Vdc ±5% at 500 mA max. (350 mA typ.)
+24 Head Supply:	+24 Vdc ±10% (see current requirements following)

The current requirement of the thermal head is approximately proportional to the percentage of dots printed. In text mode it is possible to print 25% of all the available dots (e.g., all 8's printed across the entire width), while up to 100% of the available dots can be printed in the graphics mode. The current requirements are:

Current from +24Vdc	
Average current when 25% of dots are printed:	2.9A Typ 3.2A Max
Average current when 50% of dots are printed:	5.5A Typ 6.0A Max
Average current when 100% of dots are printed:	10.7A Typ 11.5A Max
Peak Current:	16.0A Typ 18.5A Max

On board filtering is provided to ease the power supply design requirement:

+24 Vdc Supply:	500 µF Filtering
+5 Vdc Supply:	220 µF Filtering

A 4-position power connector, J2, is mounted at the rear of the printer as shown in Figure 4. Its pinout and mating information is:

Pin 1:	+5 Vdc
Pin 2:	+5 Vdc Ground
Pin 3:	+24 Vdc Ground
Pin 4:	+24 Vdc



820 DL Panel Mount Printer



820 DL Desk Top Printer



820 DL Rack Mount Printer

Connector on printer: Molex (P/N 26-60-4040)
Connector mate: Amp (P/N 640426-4)

This high force connector is specified because of the high peak currents on the +24 volt line when printing all black.

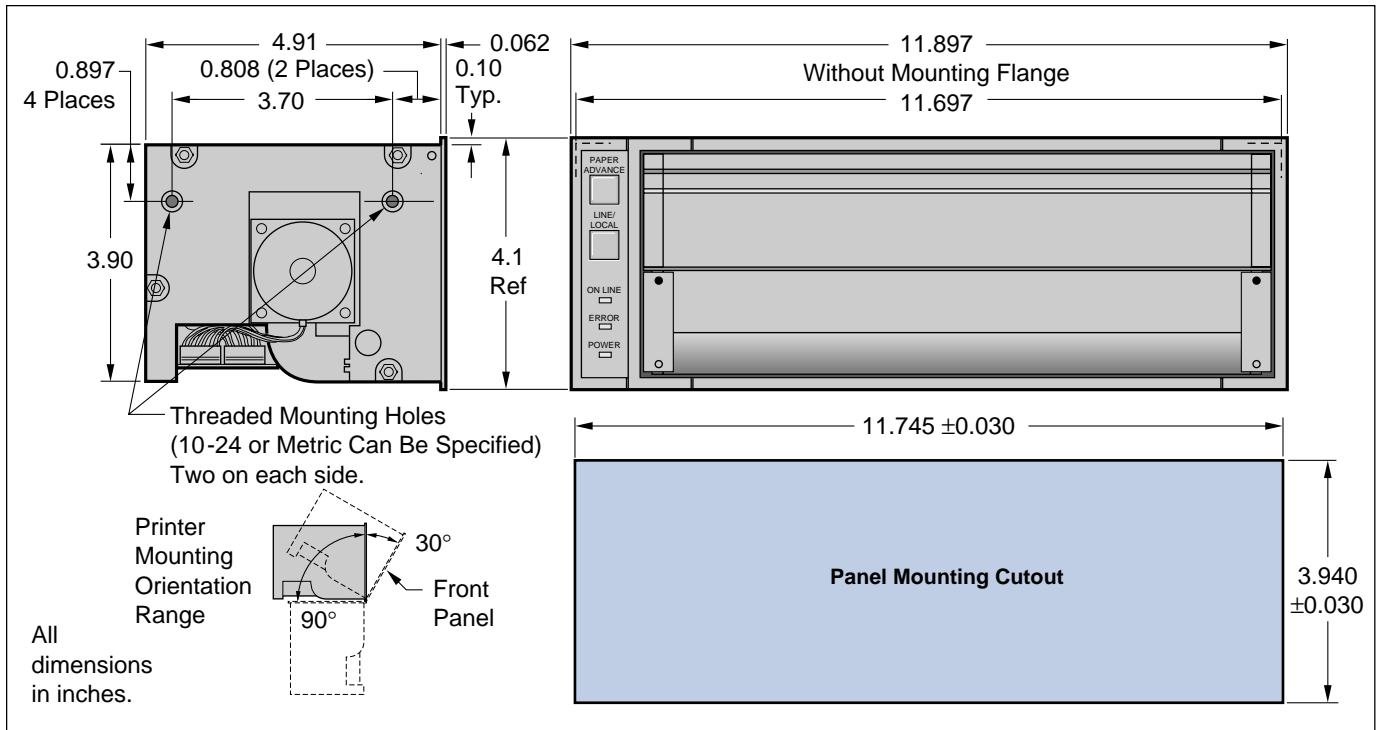

Figure 1. Panel Mounting Details

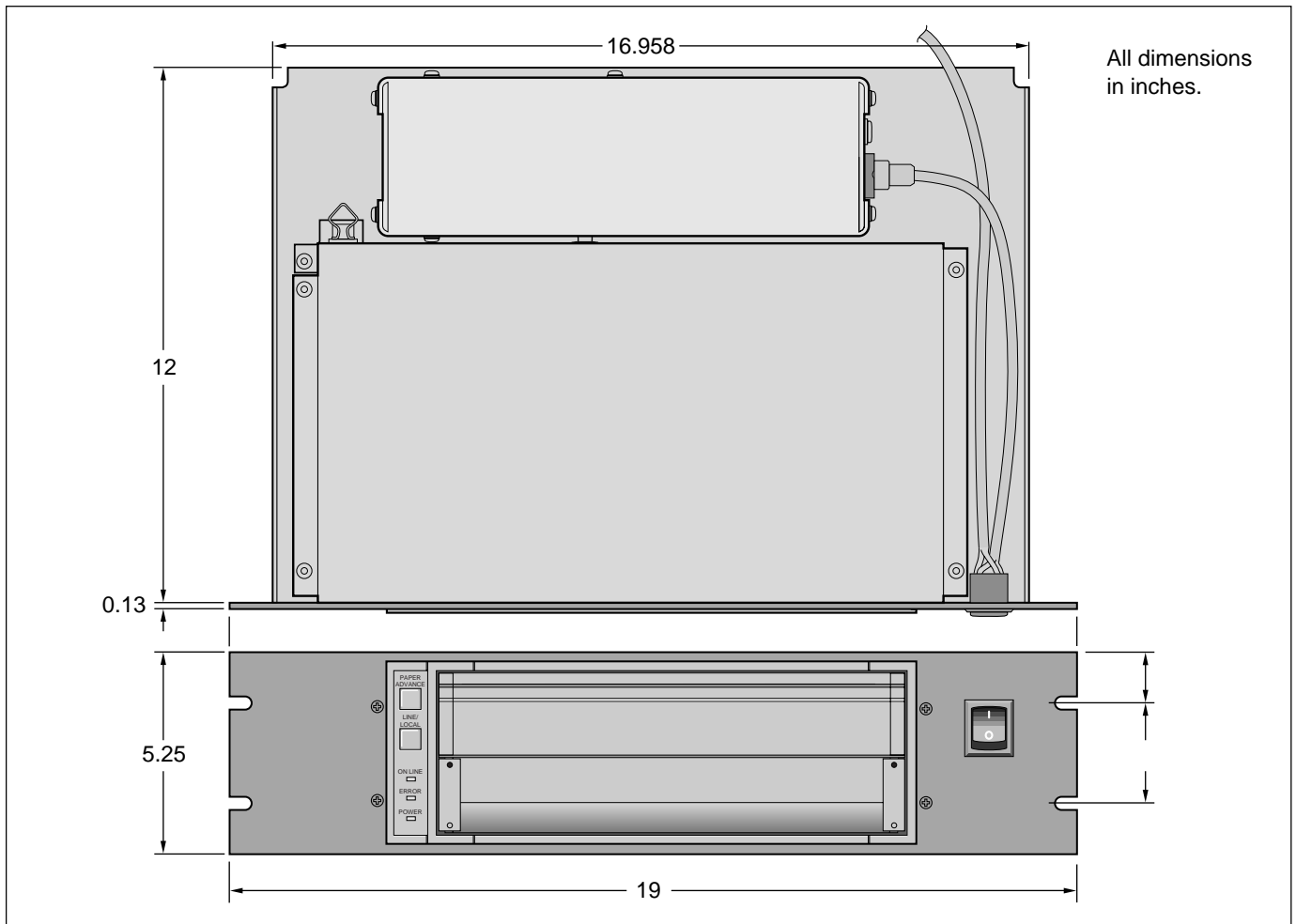

Figure 2. Rack Dimensions

Data Interface Requirements

The Centronics-type interface on the panel-mount version is through a 34-position connector, J1, mounted on the controller board at the rear of the printers. The data interface on the stand-alone and rack-mount versions is through a 36-position female Centronics-type connector, J1, mounted on the rear panel of the printer (see Figure 4). Its pinout and mating information are listed in Table 1.

Connector on panel-mount controller board:	AMP (P/N 103311-7)
Connector mating housing:	AMP (P/N 111869-8)

Input and output signal timing characteristics for the parallel interface are shown in Figure 3. The printers have an 8K byte printer buffer and continue to accept data from the host until the buffer is full. They resume data transfer when the buffer full condition is relieved.

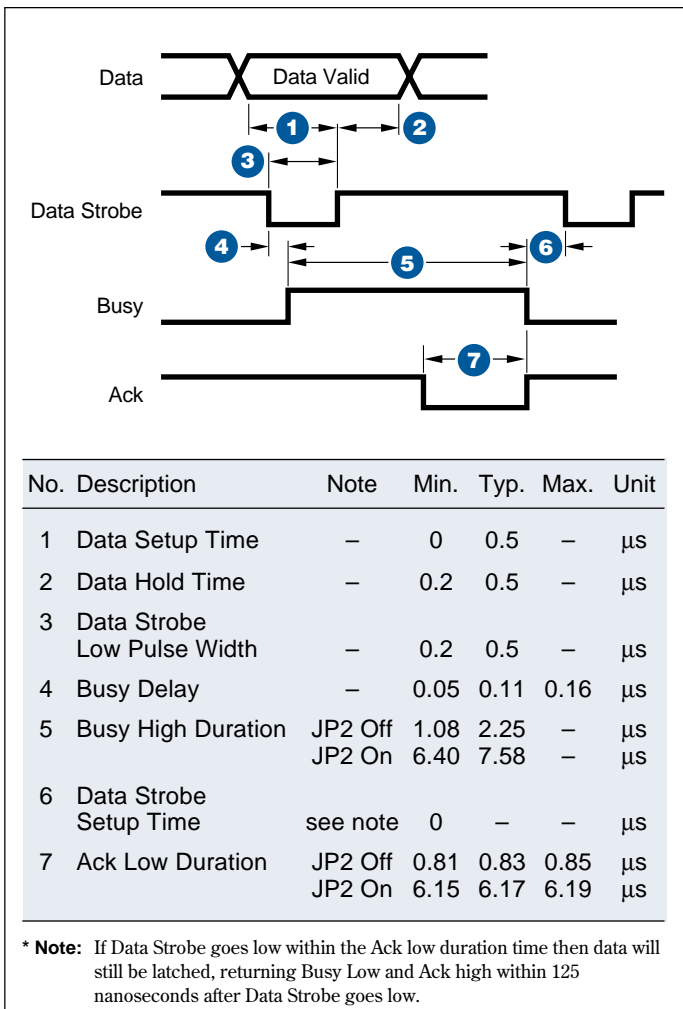

Figure 3. Parallel Interface Timing

Special Interfaces

Optional interface converters are available to adapt the standard parallel interface to other protocols. RS 232 and 20 ma current loop converters are offered.

Setting the Line Voltage and Selecting the Fuses

All configurations of the 820 DL have power input modules that permit the user to select either 115 volt or 230 volt input. They operate from either 50 Hz or 60 Hz power mains. Different types of power input modules may be used depending on printer configuration and certification by regulatory agencies. They all will have some type of removable fuse holder or voltage selector to permit selection of the appropriate voltage and installation of the correct sized fuse. The illustration in Figure 5 for UL544 and IEC 601-1 Devices is typical.

The table below shows the correct fuses to be used with different models. The correct fuse rating is also shown on the equipment chassis adjacent to the fuse holder.

Certification	115 Volt	230 Volt	Notes
IEC 601-1	1.25 amp	0.6 amp	Per IEC 127
UL 544	2.0 amp	1.0 amp	UL Listed

Typical Duty Cycle

The 820 DL is capable of printing totally black segments but the typical duty cycle should be 25% or less black. This means if some portions of the printout are entirely black, other segments should be less dense so the average is 25%. Typical text mode is less than 10% black.

Information such as circuit diagrams and parts lists that are required for trained technicians to perform normal service functions can be obtained by contacting Printrex at the address shown on the back cover of this document.

Explanation of IEC 601-1 Symbols on Equipment



Indicates Class 1 Type B equipment.



Indicates accompanying documents should be consulted.

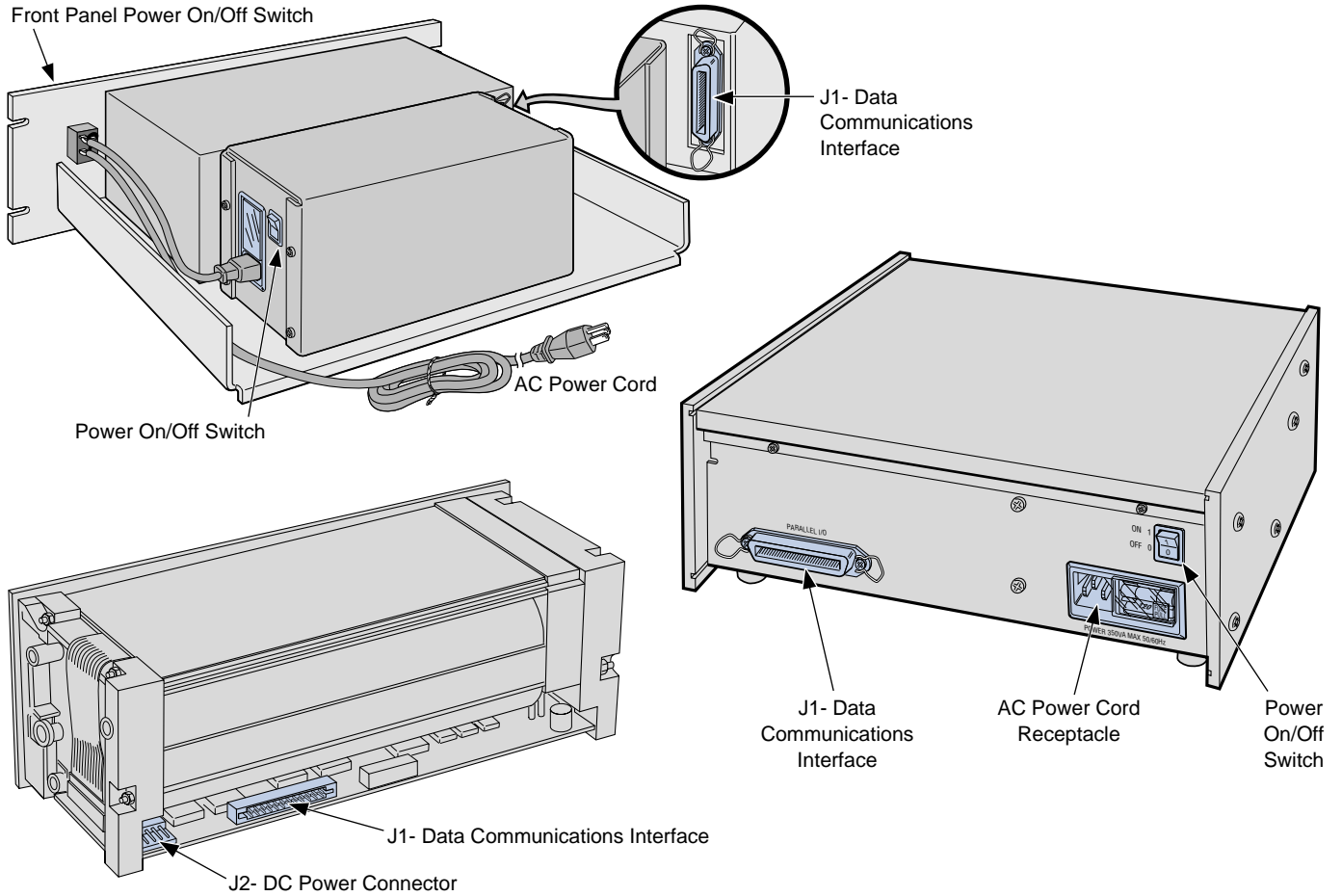

Figure 4. Power and Interface Connectors Locations

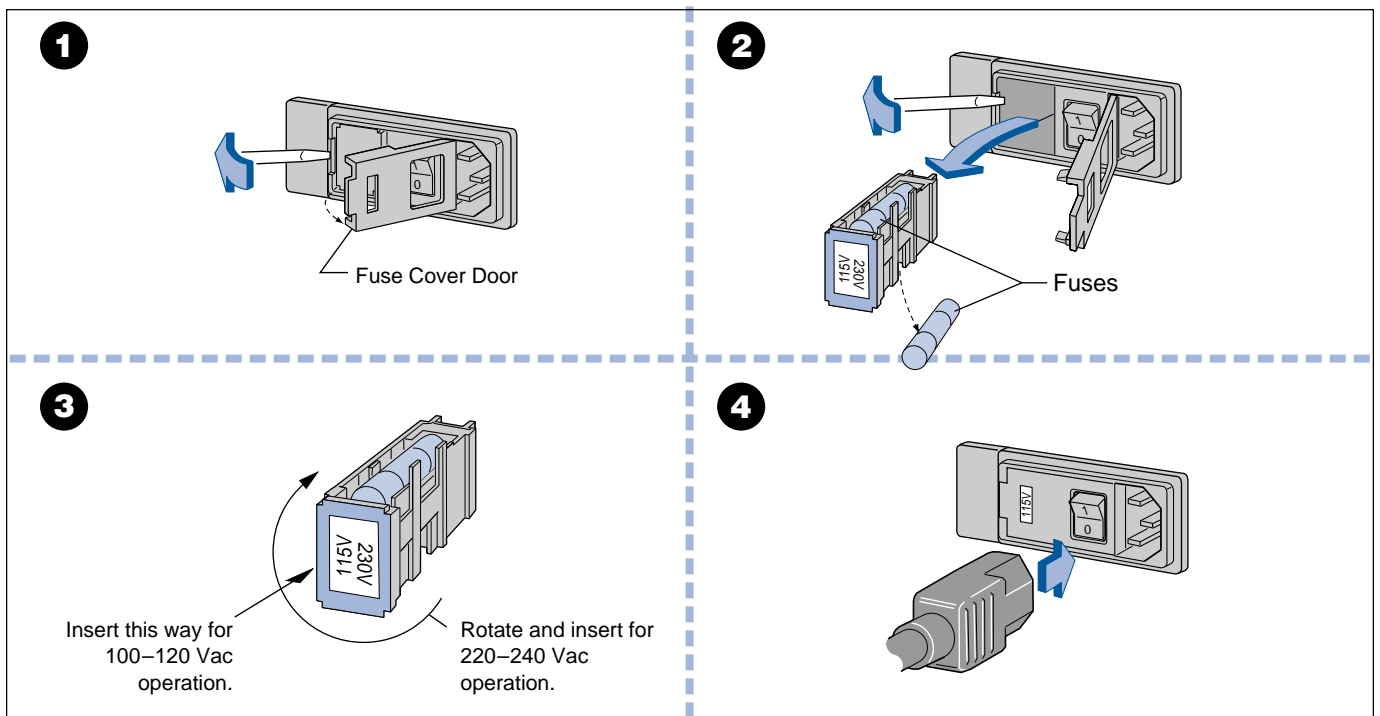

Figure 5. Selecting the Line Voltage

Table 1. Data Interface Connections **PREPARATION FOR OPERATION**

Panel Mount Pin	Stand Alone Pin	Signal	Active	I/O*	Description
1	1	Data Strobe	low	Input	Low pulse latches data
2	19	GND	-	-	Signal ground
3	2	DB0	high	Input	Data bit 0
4	20	GND	-	-	Signal ground
5	3	DB1	high	Input	Data bit 1
6	21	GND	-	-	Signal ground
7	4	DB2	high	Input	Data bit 2
8	22	GND	-	-	Signal ground
9	5	DB3	high	Input	Data bit 3
10	23	GND	-	-	Signal ground
11	6	DB4	high	Input	Data bit 4
12	24	GND	-	-	Signal ground
13	7	DB5	high	Input	Data bit 5
14	25	GND	-	-	Signal ground
15	8	DB6	high	Input	Data bit 6
16	26	GND	-	-	Signal ground
17	9	DB7	high	Input	Data bit 7
18	27	GND	-	-	Signal ground
19	10	ACK	low	Output	Acknowledge data received
20	28	GND	-	-	Signal ground
21	11	BUSY	high	Output	Printer unable to receive data
22	29	GND	-	-	Signal ground
23	12	Paper Empty	high	Output	Indicates out of paper condition
24	30	GND	-	-	Signal ground
25	13	Online	high	Output	Indicates printer selection
26	31	Init	low	Input	Initialize Printer
27	14	N.C.	-	-	
28	32	Fault	low	Output	Indicates error condition
29	15	N.C.	-	-	
30	33	N.C.	-	-	
31	16	GND	-	-	Signal ground
32	34	N.C.	-	-	
33	17	Chassis GND	-	-	Chassis ground
34	35	N.C.	-	-	
-	18	N.C.	-	-	
-	36	N.C.	-	-	

* Inputs are to printer; outputs are from printer.

Loading Paper

Loading paper rolls is extremely simple because it does not have to be threaded or aligned. To load the paper (see Figure 6):

1. Unlock the door of the printer by pressing on the open circles printed on the two latches at the lower corners of the door. Pull up on the latches to open the door.
2. Remove the paper roll holder from the printer and remove the paper roll bar from the holder. Slip the empty core off the bar.
3. Slip the paper roll bar through the core of the new paper roll and install the paper roll on the holder so the paper feeds from the top of the roll toward the front of the holder. Feed a few inches of paper from the roll so it will extend over the platen after insertion.
4. Insert the paper roll holder in the printer and close the door with the latches unlocked. Press on the solid circles printed on the door latches to lock them.
5. Tear off the extra paper. There are two tear bars; one on the bottom of the front door for tearing up and one on the printer housing for tearing down. Pull up or down at approximately a 45° angle and slightly to the right or left to tear the paper.

CAUTION: The door should be unlatched during storage to avoid temporary flat spots on the platen.

Fan Fold Forms

The 820 DL handles fan fold paper. See Figures 8 and 9.

Optional Paper Trays are available. The tray for the Desk Top 820 DL doubles as a stand for the printer. The rack for the 820 Rack Mount is attached to the underside of the printer chassis and together they require 14 (5 1/4 + 8 3/4) inches of rack space.

Forms Mark Location

The location of the forms mark is shown in Figure 7. Software in the 820 DL positions the paper so printing can begin immediately (within 0.10 in.) after the next perforation. The forms mark will normally be on alternate pages and positioned relative to the folds so that after the print job is finished and the paper stack is picked up and turned over the first page printed will always be face up.

1 Unlock Door

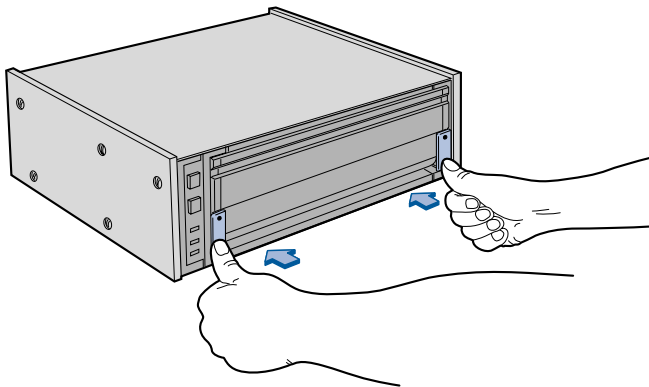

2 Insert Roll in Printer

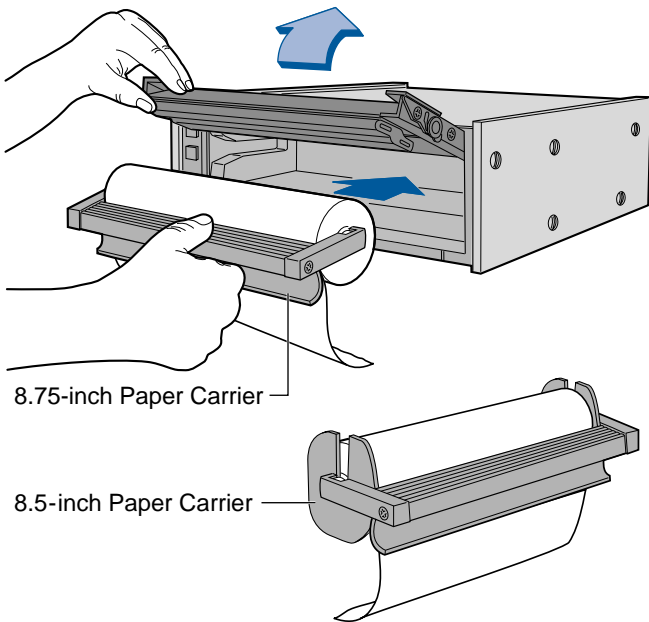

3 Lock Door

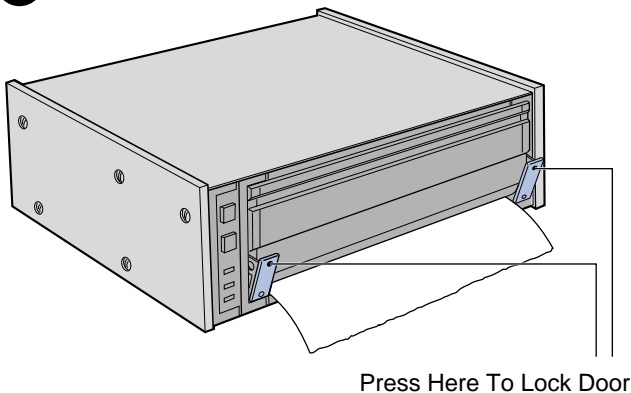

Press Here To Lock Door

Figure 6. Loading Paper into the Printer

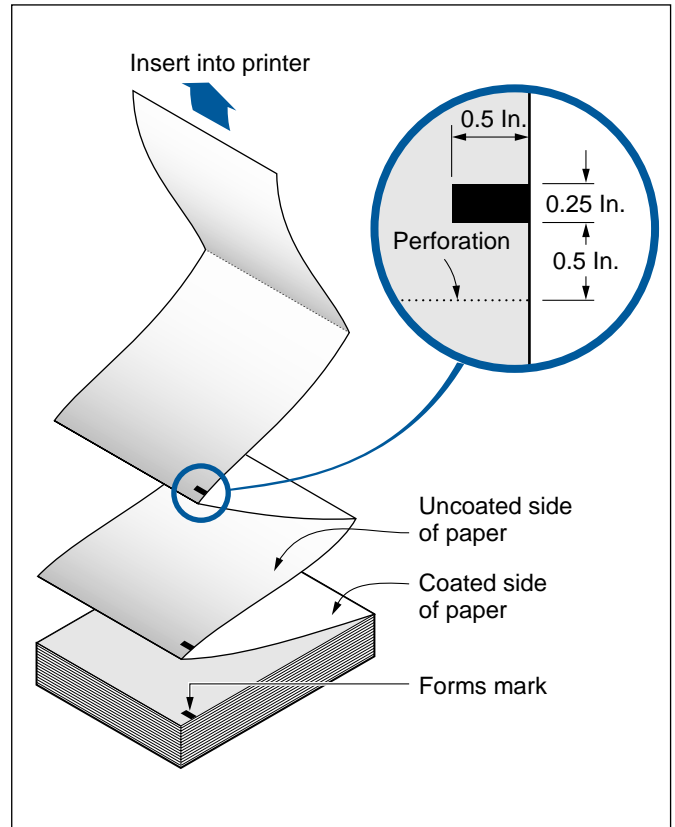

Figure 7. Forms Mark Location

Control Panel Controls and Indicators

Figure 10 shows the printer control panel. It contains two pushbutton switches (LINE/LOCAL and PAPER ADVANCE) and three indicators (POWER, ON LINE and ERROR). The POWER indicator is on whenever power is applied to the printer from either the host system or from the internal power supply. The ON LINE indicator is on whenever the printer is under control of the host system. The normal power up process places the printer in the ON LINE mode and the LINE/LOCAL switch toggles the printer between ON LINE and LOCAL.

Pressing the PAPER ADVANCE button when in the LOCAL mode causes continuous paper advance in one-character line increments. The PAPER ADVANCE button is disabled in the ON LINE mode.

When the PAPER ADVANCE button is pressed and held, paper will feed until a forms mark is encountered or until an out of paper condition exists. The PAPER ADVANCE button must be released and pressed again to advance paper to the next forms mark. The forms mark is ignored during SELF TEST.

The ERROR indicator lights continuously when the printer is out of paper and flashes under certain error conditions such as door open. Errors and their handling are described in a later paragraph.

- 1** Place printer on the stand. Position is set by the feet and side plates.

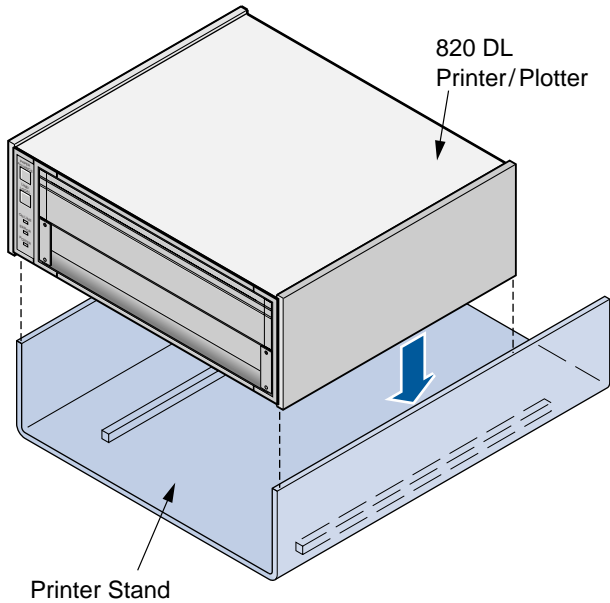

- 2** Rotate printer to upright position.

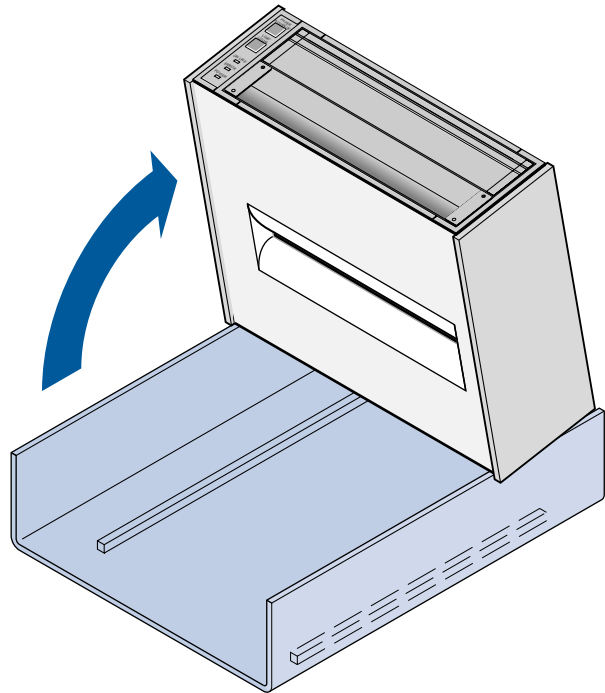

- 3** Insert paper through slot in bottom of printer and out through door.

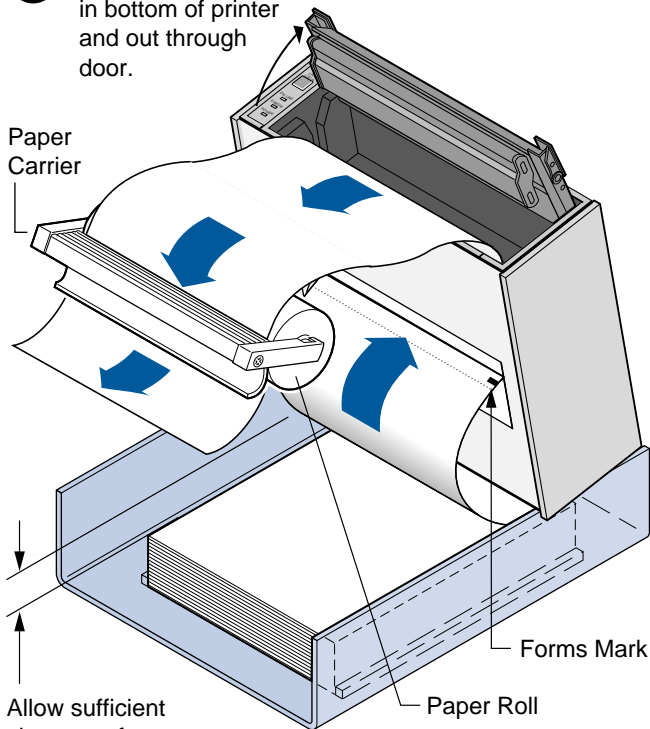

Allow sufficient clearance for the paper to unfold.

Position 11-inch forms even with the ends of the paper guides for correct position.

- 4** Return printer to horizontal, insert paper carrier and close the door. It is necessary to have a paper carrier installed to position the paper over the paper sensor.

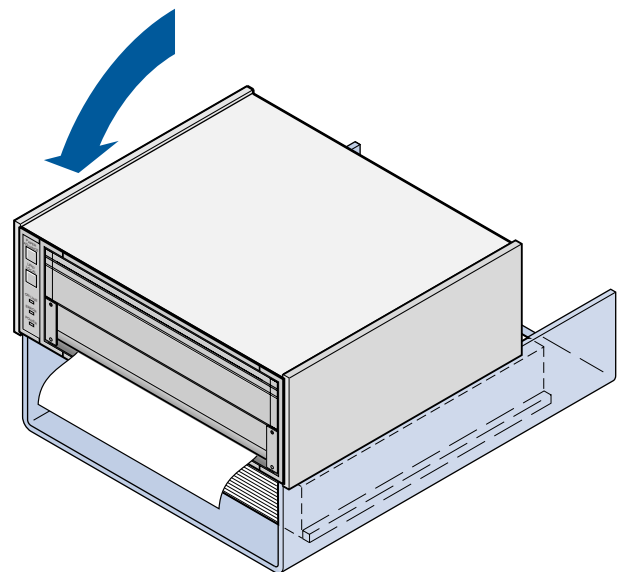

Improved paper tracking is achieved, particularly when using thin paper, if there is a full roll of paper on the paper carrier and the fan fold paper is threaded as shown in step 3.

Figure 8. 820 DL Desk Top Printer Paper Loading

1 Assembly and Installation

Paper Alignment Guides

The guides for paper alignment on the rack mount unit can be set for paper width of 8.5 inches or 8.75 inches. The guides are not symmetrical to ensure accurate installation. For 8.5-inch paper, guide "A" will be on the left and guide "B" on the right. The positions are reversed for 8.75-inch paper.

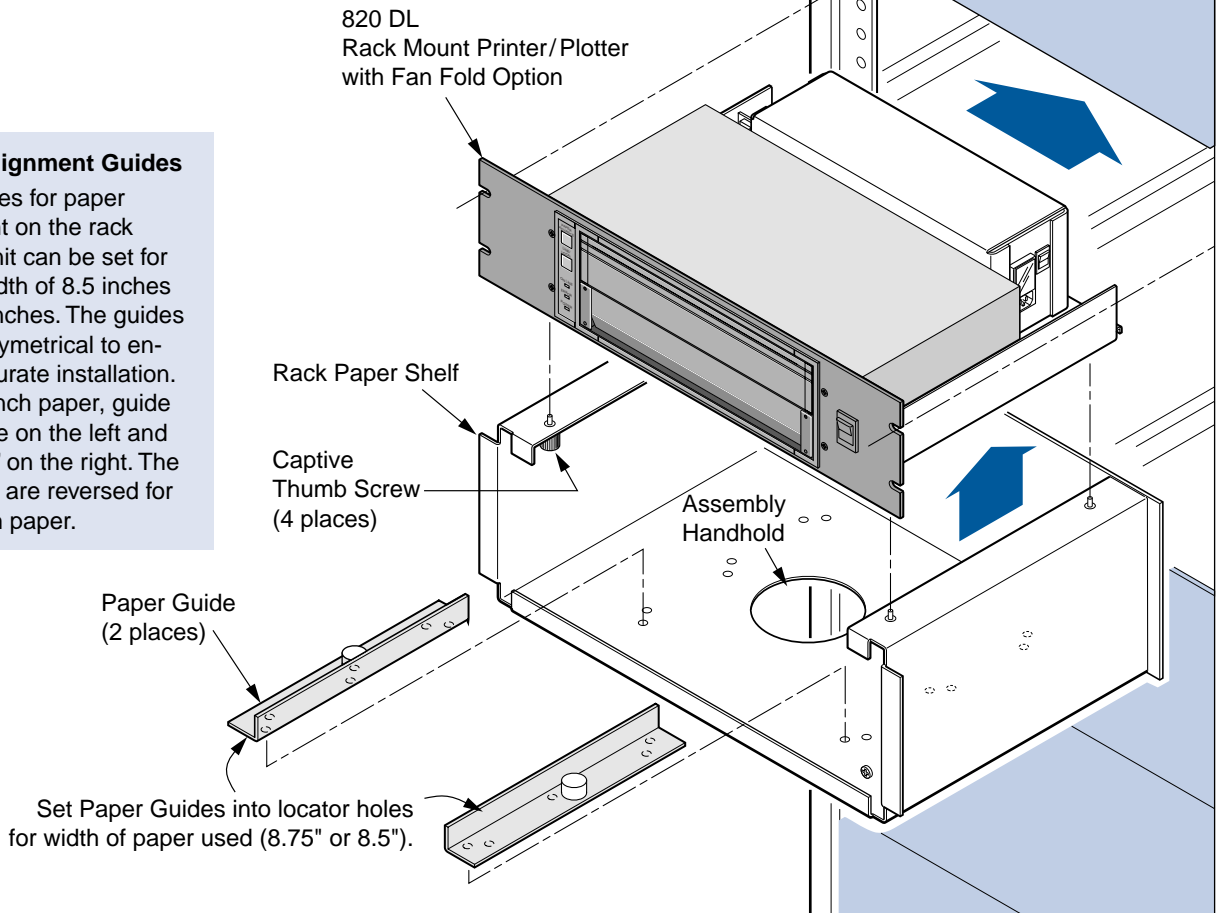

2 Insert paper through slot in bottom of printer and out through door.

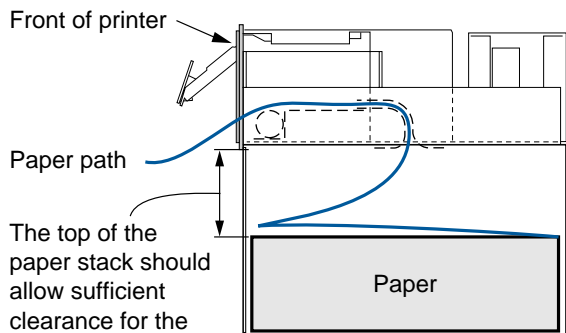

Paper must fit snugly between paper guides.

3 Insert the paper carrier and close the door.

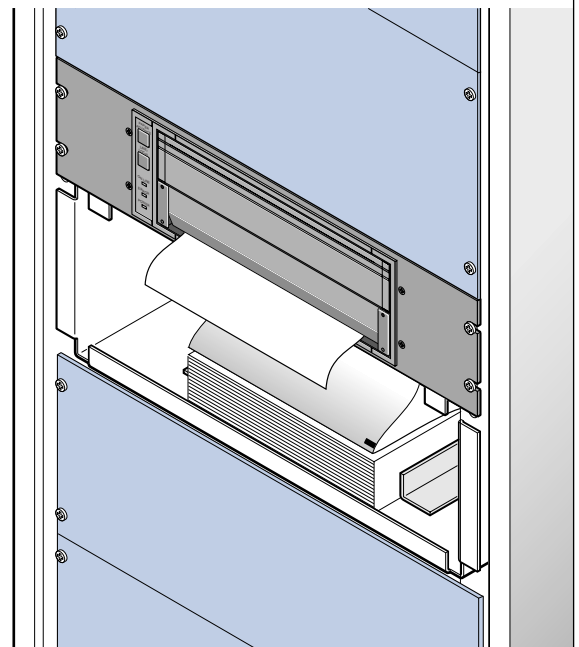

Figure 9. 820 DL Rack Mount Printer Assembly and Paper Loading

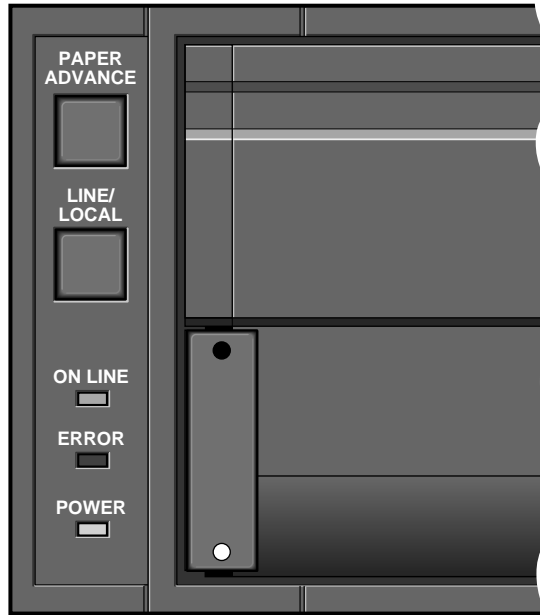

Figure 10. Front Panel Controls and Indicators

Self Test

To perform self test, place the printer in the local mode by pressing the LINE/LOCAL button. Then press and hold the PAPER ADVANCE button while pressing the LINE/LOCAL button to initiate the test. The buttons may be released once the test is started. In self test, the ERROR indicator lights and a printout of the character set and printer software identification is generated.

The self test printout continues until it is terminated by momentarily pressing the PAPER ADVANCE button again. After the self test the printer remains in local mode until the LINE/LOCAL button is again pressed.

Cleaning the Thermal Print Head

Paper dust or other foreign material may occasionally accumulate on the thermal print head. This will be indicated by light print or no print in a narrow band down the length of the paper.

Clean the thermal print head with a soft cloth moistened in 99% pure isopropyl alcohol. A light wiping along the print head is adequate. Allow the print head to dry before resuming printing. It can be wiped dry with a soft, clean cloth.

Cleaning the Exterior Surfaces

The exterior printer surfaces can be cleaned of fingerprints or spilled material by wiping them with a soft cloth moistened with a solution of mild detergent and warm water.

ERRORS AND ERROR HANDLING

The following conditions cause the front-panel ERROR indicator to light and fault signals to be sent to the host.

Paper Empty

When the printer detects a paper empty condition it stops printing, goes off line, sets the Paper Empty line high, sets the Busy line high, sets the Fault line low and lights the ERROR indicator. Normal operation resumes when a new paper roll is installed.

Door Open

When the door is opened (either latch unlocked) the printer stops printing, goes off line, sets the Fault Line low, sets the Busy line high, and flashes the ERROR indicator.

Overvoltage Error

If the +24 Vdc input is too high (+27 Volts or greater) the printer stops printing, sets the Fault line low, sets the Busy line high, flashes the ERROR indicator, and waits for the voltage to drop to operating levels.

Under Voltage

If the +24 Vdc input is too low (+21 Volts or less) for a period of 625 ms or more the printer stops printing, sets the Fault line low, sets the Busy line high, flashes the ERROR indicator, and waits for the voltage to return to +22 Volts or higher before resuming normal operation.

Over Temperature

If the printhead temperature increases above a preset level the printer runs slower than specified to allow it to cool, and returns to normal speed when the temperature reaches an acceptable level. If the printhead temperature exceeds operating levels the printer stops printing, sets the Fault line low, sets the Busy line high, flashes the ERROR indicator, and waits for the temperature to drop to operating levels before resuming normal operation.

Brown Out

A brown out condition is defined as the +5 Volt supply dropping below +4.5 Volts. The printer goes into reset and all data in its buffers is lost.

When the +5 volt supply recovers to the proper operating level the printer resumes communications with the host.

All operating conditions will be set at the power up default settings.

HOST CONTROL - ON LINE MODE**General Information**

In the ON LINE mode the printers are exclusively under the host system's control. Since they are line printers, they do not print until the line buffer is full (80 10-pitch characters have been received) or they receive a control code which requires printing. The control codes which cause printing are:

Carriage Return:	Decimal Code 13
Line Feed:	Decimal Code 10
Vertical Tab:	Decimal Code 11
Form Feed:	Decimal Code 12
Variable Vertical Line Feed:	Esc J

If more than 80 10-pitch characters are sent without one of the above codes, the first 80 characters are printed and the characters following are retained in the line buffer.

There are 224 printable characters defined by decimal codes 32 to 255. The codes from decimal 32 to 127 follow the ASCII standard for character representation. Characters 128 through 255 follow the graphic characters of the IBM ProPrinter. Special characters can be provided but they will be substituted for selected standard characters.

Six character lines are required to advance printed copy from the printhead past the paper tear bars. The six blank lines can be programmed with six CRs (Carriage Returns) or a VT (Vertical Tab).

Plotting with the 820 DL

The plot speed of the 820 DL is 1.6 inches per second. It can also plot at 3/4, 1/2 and 1/4 speed as selected by control codes to produce the optimum plot throughput. When the selected media is film the maximum print speed is 1/2 and the printer supplies more energy to the print head to produce darker lines.

The slower speeds are useful to match the input data rate when the rate is not high enough to keep the plotter running continuously at a higher speed.

Power Up Default Conditions

The printers are initialized to the following default conditions when power is applied:

Print Speed:	10 lps
Character Pitch:	10
Lines/inch	6.25
Double High Mode:	Off
Double Wide Mode:	Off
Emphasized Mode:	Off
Reverse Image Mode:	Off
Print orientation:	Upright
Graphics Mode:	Off (in Text Mode)
Selected Character Set:	Set 1
Forms Length:	11 in. (2211 dot lines)
Form Feed Interpretation:	Form Feed (n=0)
Form Feed Type:	Feed to Marker (n=0)
Form Marker Type:	"w" = 50, "lh" = 125
Media Sensitivity:	Normal (n=1)
Media Type:	Paper (n=0)

Printer Control Codes

The printers respond to the control codes listed in Table 2.

Table 2. Printer Control Codes

ASCII Mnemonic	Decimal Code	Hex Code	Description
LF	10	0A	Causes data to be printed. Ignored if after a CR.
VT	11	0B	Advances paper six blank character lines.
FF	12	0C	Causes action defined by ESC O (Set Form Feed Type) and ESC N (Form Feed Interpretation).
CR	13	0D	Prints data in the line buffer and advances the paper one character line. Ignored if after a line feed.
SO	14	0E	When sent at the beginning of a line, sets the printer to double-width print mode, otherwise ignored. A CAN, CR, LF, FF, VT or DC4 cancels double-width print.
SI	15	0F	When sent at the beginning of a line, sets the printer to compressed print mode (16.7 CPD), otherwise ignored. A DC2 cancels compressed print.
DC1	17	11	When sent at the beginning of a line, sets the printer to double-height print mode, otherwise ignored.
DC2	18	12	When sent at the beginning of a line, sets the printer to standard (10 pitch) print mode, otherwise ignored.
DC3	19	13	When sent at the beginning of a line, cancels the double-height print mode.
DC4	20	14	When sent at the beginning of a line, cancels the double-width print mode.
ETB	23	17	Returns the printer to its power up default settings.
CAN	24	18	Clears the print buffer and returns the printer to power up default conditions.
GS	29	1D	Set Top Of Form. This establishes the current line as the top of form.
ESC E	27 69	1B 45	When sent at the beginning of a line, sets the printer to the emphasized (bold) print mode.
ESC F	27 70	1B 46	When sent at the beginning of a line, cancels the emphasized print mode.
ESC G	27 71	1B 47	When sent at the beginning of a line, sets the printer to the upside down print mode.
ESC H	27 72	1B 48	When sent at the beginning of a line, cancels the upside down print mode.
ESC V n	27 86	1B 56	When sent at the beginning of a line, selects normal image if n = ASCII 0 and reverse image if n = ASCII 1.
ESC Y lh	27 89	1B 59	Sets the printer to the 100 dots/inch bit image graphics mode where l and h are low and high order binary data bytes representing the number of graphic dotlines to be printed, (h x 256) + l. For example, Esc Y 3 1 would create 259 graphic dotlines. The sequence would then be followed by 259 x 108 = 27972 graphic data bytes. Each dotline is 864 dots or 108 bytes wide.
ESC Z lh	27 90	1B 5A	Sets the printer to the 200 dots/inch bit image graphics mode where l and h are low and high order binary data bytes representing the number of graphic dotlines to be printed, (h x 256) + l. For example, Esc Z 3 1 would create 259 graphic dotlines. The sequence would then be followed by 259 x 216 = 55944 graphic data bytes. Each dotline is 1728 dots or 216 bytes wide.
ESC 6	27 54	1B 36	When sent at the beginning of a line, selects character set 2 (see Table 3).
ESC 7	27 55	1B 37	When sent at the beginning of a line, selects character set 1 (see Table 3).

Table 2. Printer Control Codes (Continued)

ASCII Mnemonic	Decimal Code	Hex Code	Description
ESC 9 n	27 57	1B 39	When sent at the beginning of a line, selects 12 lines/inch if n = ASCII 1 and selects 6 lines/inch if n = ASCII 0.
ESC \$	27 36	1B 24	Selects hex dump. Prints all data received in hexadecimal format. This mode is exited by toggling the LINE/LOCAL button.
ESC <	27 60	1B 3C	When sent at the beginning of a line, sets the printer to the plot mode (up to 0.4 ips).
ESC *	27 42	1B 2A	When sent at the beginning of a line, selects the 1/2 speed print mode (0.8 ips).
ESC >	27 62	1B 3E	When sent at the beginning of a line, selects the 3/4 speed print mode (1.2 ips).
ESC +	27 43	1B 2B	When sent at the beginning of a line, selects the full speed print mode (1.6 ips).
ESC :	27 58	1B 3A	When sent at the beginning of a line, selects 12 characters/inch pitch. DC2 resets the printer to 10 characters/inch.
ESC /	27 47	1B 2F	When sent at the beginning of a line, selects 20 characters/inch pitch. DC2 resets the printer to 10 characters/inch.
ESC T n	27 84	1B 54	Type of Media. n sets the type of media. n = 0 is paper, 1 is film. When film is set, the maximum speed of the printer will be half speed and increased energy is applied to the print head. Default is paper.
ESC S n	27 83	1B 53	Sensitivity of Media. n sets the printer intensity. n = { 0 - Low, 1 - Normal, 2 - High}. Low is used when the media has a low sensitivity to heat, and increases the burn time. High is used when the media has a high sensitivity to heat, and decreases the burn time. Default is Normal.
ESC L lh	27 76	1B 4C	Set Forms Length. l and h are the low and high binary bytes respectively of the form length in 1/201 inch units. Default is 11 inches or 2,211 decimal dotlines. This operates with the form feed defined with ESC O n where n = 1.
ESC O n	27 79	1B 4F	Set Form Feed Type. This command determines the method of handling the form feed when the ESC N n command has n set to 0. (See Esc N, Set Form Feed Interpretation.) n = 0 - Feeds to form marker or 16.1", whichever is first. n = 1 - Feeds to the next top of form. Top of form is defined using the page length, and form marker. When the form marker is detected, the distance from marker to top of form will override any determination of top of form using the page length.
ESC N n	27 78	1B 4E	Set FF Interpretation. This command determines how the Form Feed will be interpreted. n = 0 - The form feed will be interpreted as a Form Feed (See Set Form Feed Type). n = 1 - The Form Feed will be interpreted as a Carriage Return. n = 2 - The Form Feed will be interpreted as a Vertical Tab. n = 3 - the Form Feed will be ignored.
ESC M wlh	27 77	1B 4D	Set Form Marker Type. This command sets the characteristics of the form marker in 1/201 inch increments. 'w' is the marker width. 'l' is the low binary byte of the 'Marker Distance', and 'h' is the high byte. 'Marker Distance' is the distance from the center of the form marker to the paper perforation. The range of 'w' is 50 - 200. Default: w = 50. 'lh' = 125.
ESC J n	27 74	1B 4A	Variable Vertical Line Feed, 'n' is the number of blank dotlines (1/201 inch) to be printed. n = 0 - 255.
ESC ?	27 63	1B 3F	Resume Previous Speed Setting. This code returns the printer to the speed it was printing at prior to the last speed change command.

Table 3. Character Set 1 (IBM) and 2 (International)

Decimal Code	Hex Code	Character Set 1	Character Set 2	Decimal Code	Hex Code	Character Set 1	Character Set 2	Decimal Code	Hex Code	Character Set 1	Character Set 2
0	00	NUL	NUL	45	2D	-	-	90	5A	Z	Z
1	01			46	2E	.	.	91	5B	[
2	02			47	2F			92	5C	\	\
3	03		•	48	30	Ø	Ø	93	5D]]
4	04		•	49	31	1	1	94	5E	ˆ	ˆ
5	05		±	50	32	2	2	95	5F	˘	˘
6	06		•	51	33	3	3	96	60	˙	˙
7	07	BEL	BEL	52	34	4	4	97	61	¸	¸
8	08	BS	BS	53	35	5	5	98	62	¸	¸
9	09	HT	HT	54	36	6	6	99	63	¸	¸
10	0A	LF	LF	55	37	7	7	100	64	d	d
11	0B	VT	VT	56	38	8	8	101	65	e	e
12	0C	FF	FF	57	39	9	9	102	66	f	f
13	0D	CR	CR	58	3A			103	67	g	g
14	0E	SO	SO	59	3B			104	68	h	h
15	0F	SI	SI	60	3C	\	\	105	69	i	i
16	10			61	3D	=	=	106	6A	j	j
17	11	DC1	DC1	62	3E	˘	˘	107	6B	k	k
18	12	DC2	DC2	63	3F	˙	˙	108	6C	l	l
19	13	DC3	DC3	64	40	Ø	Ø	109	6D	m	m
20	14	DC4	DC4	65	41	A	A	110	6E	n	n
21	15			66	42	B	B	111	6F	o	o
22	16			67	43	ˆ	ˆ	112	70	p	p
23	17			68	44	˘	˘	113	71	q	q
24	18	CAN	CAN	69	45	F	E	114	72	r	r
25	19			70	46	F	F	115	73	s	s
26	1A			71	47	E	E	116	74	t	t
27	1B	ESC	ESC	72	48	H	H	117	75	u	u
28	1C			73	49	I	I	118	76	v	v
29	1D			74	4A	J	J	119	77	w	w
30	1E			75	4B	K	K	120	78	x	x
31	1F			76	4C	L	L	121	79	y	y
32	20	SP	SP	77	4D	M	M	122	7A	z	z
33	21	ˆ	ˆ	78	4E	N	N	123	7B	:	:
34	22			79	4F	O	O	124	7C		
35	23	#	#	80	50	P	P	125	7D	:	:
36	24	•	•	81	51	Q	Q	126	7E	ˆ	ˆ
37	25	˘	˘	82	52	R	R	127	7F		
38	26	˙	˙	83	53	S	S	128	80	NUL	Ç
39	27	ˆ	ˆ	84	54	T	T	129	81		U
40	28	˘	˘	85	55	U	U	130	82	¸	¸
41	29	˙	˙	86	56	v	v	131	83	¸	¸
42	2A	¸	¸	87	57	w	w	132	84	¸	¸
43	2B	ˆ	ˆ	88	58	X	X	133	85	ˆ	ˆ
44	2C	.	.	89	59	Y	Y	134	86	ˆ	ˆ

Table 3. Character Set 1 (IBM) and 2 (International) (Continued)

Decimal Code	Hex Code	Character Set 1	Character Set 2	Decimal Code	Hex Code	Character Set 1	Character Set 2	Decimal Code	Hex Code	Character Set 1	Character Set 2
135	87	Ç	Ć	180	B4	┌	┌	225	E1	⊞	⊞
136	88	ç	ć	181	B5	┐	┐	226	E2	┌	┌
137	89	¸	¸	182	B6	┘	┘	227	E3	┐	┐
138	8A	¸	¸	183	B7	┘	┘	228	E4	┘	┘
139	8B	¸	¸	184	B8	┘	┘	229	E5	┘	┘
140	8C	¸	¸	185	B9	┘	┘	230	E6	┘	┘
141	8D	¸	¸	186	BA	┘	┘	231	E7	┘	┘
142	8E	¸	¸	187	BB	┘	┘	232	E8	┘	┘
143	8F	¸	¸	188	BC	┘	┘	233	E9	┘	┘
144	90	¸	¸	189	BD	┘	┘	234	EA	┘	┘
145	91	¸	¸	190	BE	┘	┘	235	EB	┘	┘
146	92	¸	¸	191	BF	┘	┘	236	EC	┘	┘
147	93	¸	¸	192	C0	┘	┘	237	ED	┘	┘
148	94	¸	¸	193	C1	┘	┘	238	EE	┘	┘
149	95	¸	¸	194	C2	┘	┘	239	EF	┘	┘
150	96	¸	¸	195	C3	┘	┘	240	F0	┘	┘
151	97	¸	¸	196	C4	┘	┘	241	F1	┘	┘
152	98	¸	¸	197	C5	┘	┘	242	F2	┘	┘
153	99	¸	¸	198	C6	┘	┘	243	F3	┘	┘
154	9A	¸	¸	199	C7	┘	┘	244	F4	┘	┘
155	9B	¸	¸	200	C8	┘	┘	245	F5	┘	┘
156	9C	¸	¸	201	C9	┘	┘	246	F6	┘	┘
157	9D	¸	¸	202	CA	┘	┘	247	F7	┘	┘
158	9E	¸	¸	203	CB	┘	┘	248	F8	┘	┘
159	9F	¸	¸	204	CC	┘	┘	249	F9	┘	┘
160	A0	¸	¸	205	CD	┘	┘	250	FA	┘	┘
161	A1	¸	¸	206	CE	┘	┘	251	FB	┘	┘
162	A2	¸	¸	207	CF	┘	┘	252	FC	┘	┘
163	A3	¸	¸	208	D0	┘	┘	253	FD	┘	┘
164	A4	¸	¸	209	D1	┘	┘	254	FE	┘	┘
165	A5	¸	¸	210	D2	┘	┘	255	FF	SP	SP
166	A6	¸	¸	211	D3	┘	┘				
167	A7	¸	¸	212	D4	┘	┘				
168	A8	¸	¸	213	D5	┘	┘				
169	A9	┌	┌	214	D6	┘	┘				
170	AA	┌	┌	215	D7	┘	┘				
171	AB	┌	┌	216	D8	┘	┘				
172	AC	┌	┌	217	D9	┘	┘				
173	AD	┌	┌	218	DA	┘	┘				
174	AE	┌	┌	219	DB	┘	┘				
175	AF	┌	┌	220	DC	┘	┘				
176	B0	┌	┌	221	DD	┘	┘				
177	B1	┌	┌	222	DE	┘	┘				
178	B2	┌	┌	223	DF	┘	┘				
179	B3	┌	┌	224	E0	┘	┘				

820 DL Thermal Printer/Plotter

PERFORMANCE SPECIFICATIONS

Alphanumeric Mode

Print rate: 10, 7.5, 5 or 2.5 character lines/second

96 ASCII characters and 128 graphic characters

Double high and double wide print

Inverted and reverse image characters

International character sets

6.25 or 12.5 character lines/inch

Line length is 8 inches (Nominal)

Character Format

Alphanumeric Character Format:

Pitch	Number of Dots Wide	Number of Dots High	Number of Characters/Line
10	20	32	80
12	16	32	100
16.7	12	32	140
20	10	32	160

Graphics Characters: May occupy any position in the above matrices

Bit Mapped Graphics Mode

Plot speed: 1.6, 1.2, 0.8 or 0.4 inches/second

100 x 100 dots/inch or 200 x 200 dots/inch (nominal)

Horizontal dot density: 203 dots/inch (8 dots/mm)

Vertical dot density: 201 dots/inch (8 dots/mm)

Line length: 8.5 inches (216 mm)

Hardware Interface

Centronics type parallel. RS 232 and 20 ma Current Loop serial/parallel converters are offered.

Print Drivers

Printer drivers are available for the various Windows® operating systems. Please consult the Printrex web page to download the current revision for your operating system.

Windows is a registered trademark of Microsoft Corporation.

Regulatory Approvals

CE Mark

IEC 601-1

UL 544

CSA 22.2

Media Specifications

Standard thermal rolls, fan fold forms and thermal transparencies.

Media Dimensions: 8.75" (222 mm) or 8.5" (216 mm) wide with appropriate paper carriers

Maximum Roll Diameter: 2.6" (66mm)

Physical Characteristics

Dimensions:

Panel-mount printer	4.1" H x 11.9" W x 4.97" D (10.4 x 30.2 x 12.6 cm)
Desktop version	4.87" H x 12.3" W x 12.0" D (12.4 x 31.2 x 30.5 cm)
Rack-mount configuration	5.25" H x 19" W x 12" D (13.3 x 48.3 x 30.5 cm)

Shipping Weight:

Panel-mount	7 lbs. (3.2 kg)
Stand-alone	21 lbs. (9.5 kg)
Rack-mount	22 lbs. (10 kg)

Environmental

Operating Temperature: +41 to +104°F (+5 to +40°C)

Storage Temperature: -40 to +140°F (-40 to +60°C)

Acceleration (Non-Operating): +3G, 0 to 50 Hz, 3 axes

Part Numbers

2011-0058	820 DL Desk Top Printer / Plotter
2011-0060	820 DL Panel Mount Unit
2011-0061	820 DL Rack Mount Configuration



276 East Gish Road
San Jose, California 95112
(408) 573-1200 Voice
(408) 573-1600 Fax

www.printrex.com